

CLIENT



ENGINEERS



LEGEND

**TREE CONDITION CATEGORIES**

- A TREES OF HIGH VALUE AND QUALITY
- B TREES OF MODERATE VALUE AND QUALITY
- C TREES OF LOW QUALITY AND VALUE
- U TREES OF VERY LOW VALUE AND QUALITY TO BE REMOVED IN THE INTERESTS OF SOUND ARBORICULTURAL MANAGEMENT

- TREE CONSTRAINTS
- SITE BOUNDARY

Drawing to be interpreted with reference to Tree Survey document

Tree constraints shown are calculated from guidelines contained within BS5837 (2012) within dimensions contained within Section 8 of the Tree Survey document. This outline should not be interpreted as the exact extent of root spread however it is considered the optimal area to be retained free of developmental impacts.

Natural and/or man made barriers such as waterlogged soil or buildings may restrict the spread of tree roots. Crown spreads may also prove to be a constraint particularly where crown reduction may not be possible.

The constraints lines shown on this drawing are therefore a guide only. An on-site assessment should be undertaken in the event of any developments being planned within the areas shown for retained trees.

AREA 1

AREA 2

AREA 3

REVISIONS

REV	DATE	DESCRIPTION

PROJECT: Limekiln Rd/Templeogue Wood Road/Rossmore Road upgrade		JOB NO. TWEL002
DRAWING: ARBORICULTURAL ASSESSMENT (KEYPLAN)	DATE: 17-11-21	SCALE: as shown @ A1
DRAWN BY: NIALL MCBRIDE		NMB INITIALS
STATUS: PLANNING		REVISION.
DRAWING NO. 101		

**NOTES**  
Do Not Scale - Use Figured Dimensions Only  
Not for Construction - Purpose unless Specifically Marked  
© THIS DRAWING IS COPYRIGHT OF CMK HORTICULTURE + ARBORICULTURE LTD.

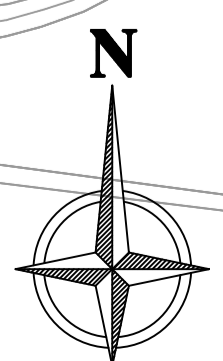



CLIENT



ENGINEERS

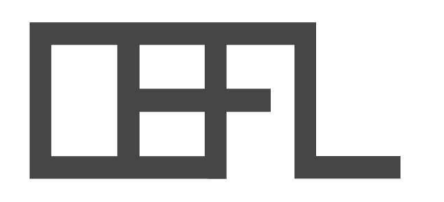

LEGEND

- TREE CONDITION CATEGORIES**
- A TREES OF HIGH VALUE AND QUALITY
  - B TREES OF MODERATE VALUE AND QUALITY
  - C TREES OF LOW QUALITY AND VALUE
  - U TREES OF VERY LOW VALUE AND QUALITY TO BE REMOVED IN THE INTERESTS OF SOUND ARBORICULTURAL MANAGEMENT

- TREE CONSTRAINTS
- SITE BOUNDARY

Drawing to be interpreted with reference to Tree Survey document  
 Tree constraints shown are calculated from guidelines contained within BS5837:2012 within dimensions contained within Section 8 of the Tree Survey document. This outline should not be interpreted as the exact extent of root spread however it is considered the optimal area to be retained free of developmental impacts.  
 Natural and/or man made barriers such as waterlogged soil or buildings may restrict the spread of tree roots. Crown spreads may also prove to be a constraint particularly where crown reduction may not be possible. The constraints lines shown on this drawing are therefore a guide only. An on-site assessment should be undertaken in the event of any developments being planned within the areas shown for retained trees.

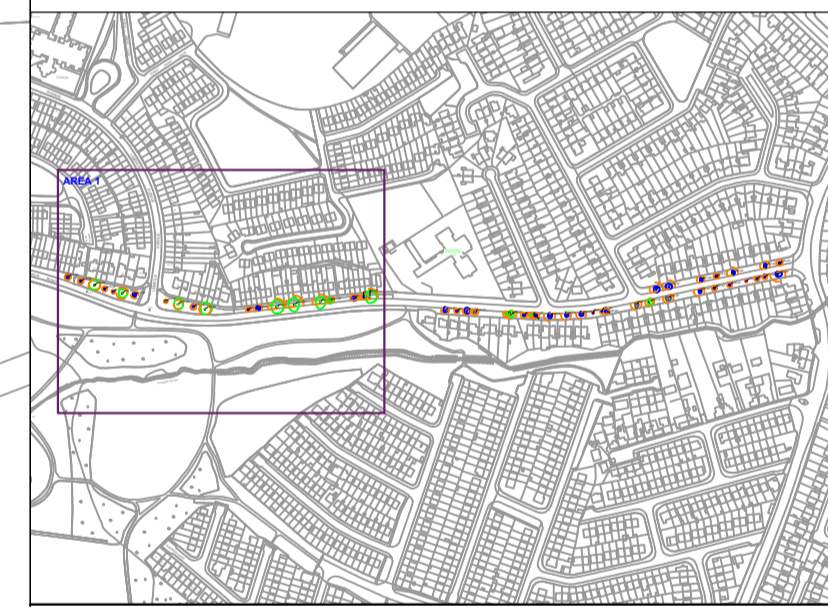

REVISIONS

REV	DATE	DESCRIPTION

PROJECT: LIMEKILN RD/TEMPLEGGUE WOOD ROAD/ROSSMORE ROAD UPGRADE		JOB NO. TWEL002
DRAWING: ARBORICULTURAL ASSESSMENT (1of3)	DATE: 17-11-21	SCALE: 1:425@ A1
DRAWN BY: NIALL MCBRIDE		NMB INITIALS
STATUS: PLANNING		REVISION:
DRAWING NO. 102		

**NOTES**  
 Do Not Scale. Use Figured Dimensions Only.  
 Not for Construction. Purpose unless Specifically Marked.  
 © THIS DRAWING IS COPYRIGHT OF CMK HORTICULTURE + ARBORICULTURE LTD.



CLIENT







ENGINEERS



LEGEND

**TREE CONDITION CATEGORIES**

-  **A TREES OF HIGH VALUE AND QUALITY**
-  **B TREES OF MODERATE VALUE AND QUALITY**
-  **C TREES OF LOW QUALITY AND VALUE**
-  **U TREES OF VERY LOW VALUE AND QUALITY TO BE REMOVED IN THE INTERESTS OF SOUND ARBORICULTURAL MANAGEMENT**

-  **TREE CONSTRAINTS**
-  **SITE BOUNDARY**

Drawing to be interpreted with reference to Tree Survey document

Tree constraints shown are calculated from guidelines contained within BS5837 (2012) within dimensions contained within Section 8 of the Tree Survey document. This outline should not be interpreted as the exact extent of root spread however it is considered the optimal area to be retained free of developmental impacts.

Natural and/or man made barriers such as waterlogged soil or buildings may restrict the spread of tree roots. Crown spreads may also prove to be a constraint particularly where crown reduction may not be possible.

The constraints lines shown on this drawing are therefore a guide only. An on-site assessment should be undertaken in the event of any developments being planned within the areas shown for retained trees.

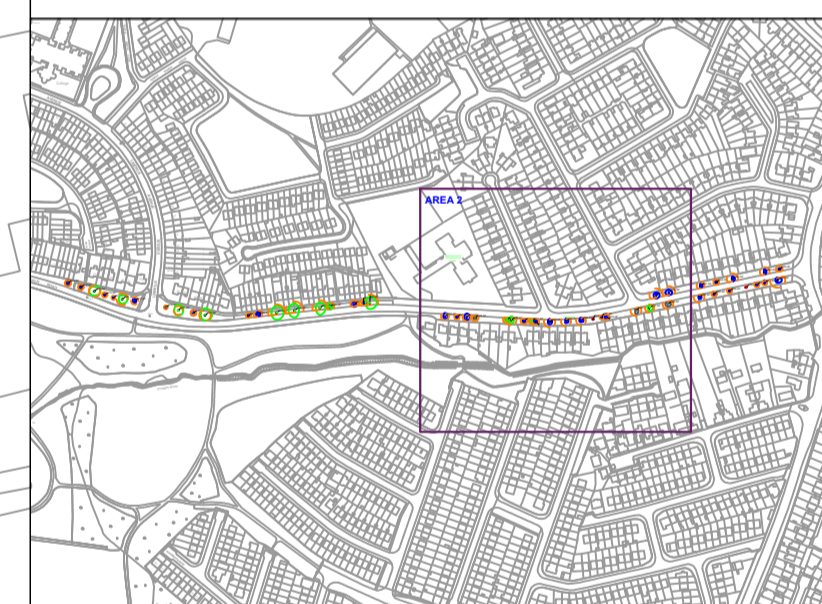

REVISIONS

REV	DATE	DESCRIPTION

PROJECT: LIMEKILN RD/TEMPLEGGUE WOOD ROAD/ROSSMORE ROAD UPGRADE		JOB NO. TWEL002
DRAWING: ARBORICULTURAL ASSESSMENT (2of3)	DATE: 17-11-21	SCALE: 1:425@ A1
DRAWN BY: NIALL MCBRIDE		NMB INITIALS
STATUS: PLANNING		REVISION:
DRAWING NO. 103		

**NOTES**  
Do Not Scale: Use Figured Dimensions Only.  
Not for Construction: Purposes unless Specifically Marked.  
© THIS DRAWING IS COPYRIGHT OF CMK HORTICULTURE + ARBORICULTURE LTD.



RIVERVIEW EDUCATE  
TOGETHER NATIONAL  
SCHOOL

LIMEKILN ROAD

- 531 AP
- 532 AP
- 533 AP
- 534 AP
- 535 AP
- 536 AP
- 537 AP
- 538 AP
- 539 AP
- 540 AP
- 541 AP
- 542 AP
- 543 AP
- 544 AP
- 545 AP
- 546 AP
- 547 AP
- 548 AP
- 549 AP
- 550 AP

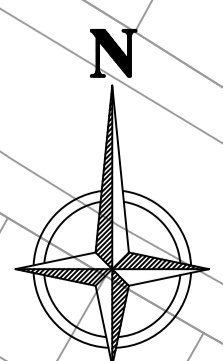

CLIENT



ENGINEERS



LEGEND

**TREE CONDITION CATEGORIES**

- A TREES OF HIGH VALUE AND QUALITY
- B TREES OF MODERATE VALUE AND QUALITY
- C TREES OF LOW QUALITY AND VALUE
- U TREES OF VERY LOW VALUE AND QUALITY TO BE REMOVED IN THE INTERESTS OF SOUND ARBORICULTURAL MANAGEMENT

- TREE CONSTRAINTS
- SITE BOUNDARY

Drawing to be interpreted with reference to Tree Survey document

Tree constraints shown are calculated from guidelines contained within BS5837 (2012) within dimensions contained within Section 8 of the Tree Survey document. This outline should not be interpreted as the exact extent of root spread however it is considered the optimal area to be retained free of developmental impacts.

Natural and/or man made barriers such as waterlogged soil or buildings may restrict the spread of tree roots. Crown spreads may also prove to be a constraint particularly where crown reduction may not be possible. The constraints lines shown on this drawing are therefore a guide only. An on-site assessment should be undertaken in the event of any developments being planned within the areas shown for retained trees.

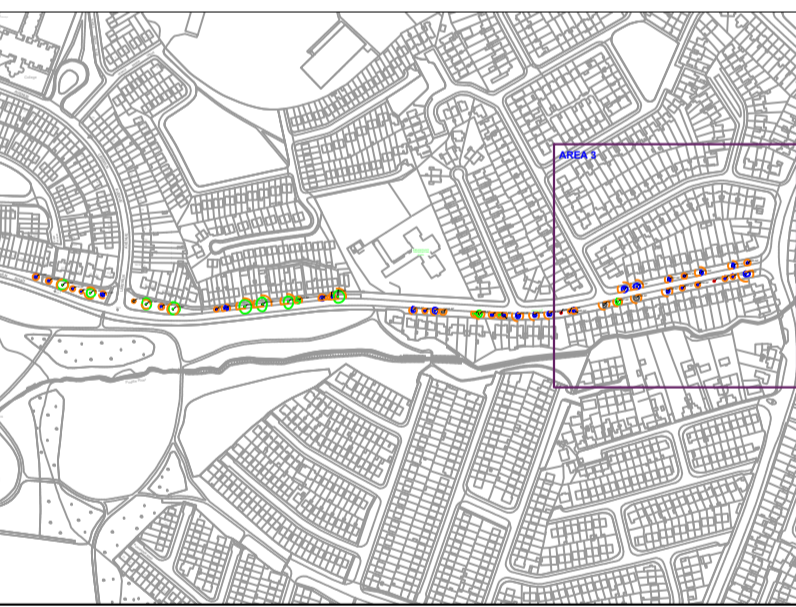

REVISIONS

REV	DATE	DESCRIPTION

PROJECT: LIMEKILN RD/TEMPLEOGUE WOOD ROAD/ROSSMORE ROAD UPGRADE		JOB NO. TWEL002
DRAWING: ARBORICULTURAL ASSESSMENT (3of3)	DATE: 17-11-21	SCALE: 1:425@ A1
DRAWN BY: NIALL MCBRIDE		NMB INITIALS
STATUS: PLANNING		REVISION:
DRAWING NO. 104		

NOTES  
Do Not Scale. Use Figured Dimensions Only.  
Not for Construction. Purpose unless Specifically Marked.  
© THIS DRAWING IS COPYRIGHT OF CMK HORTICULTURE + ARBORICULTURE LTD.

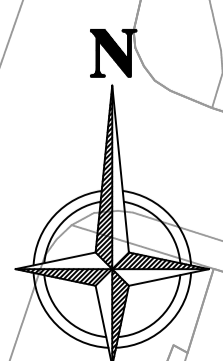

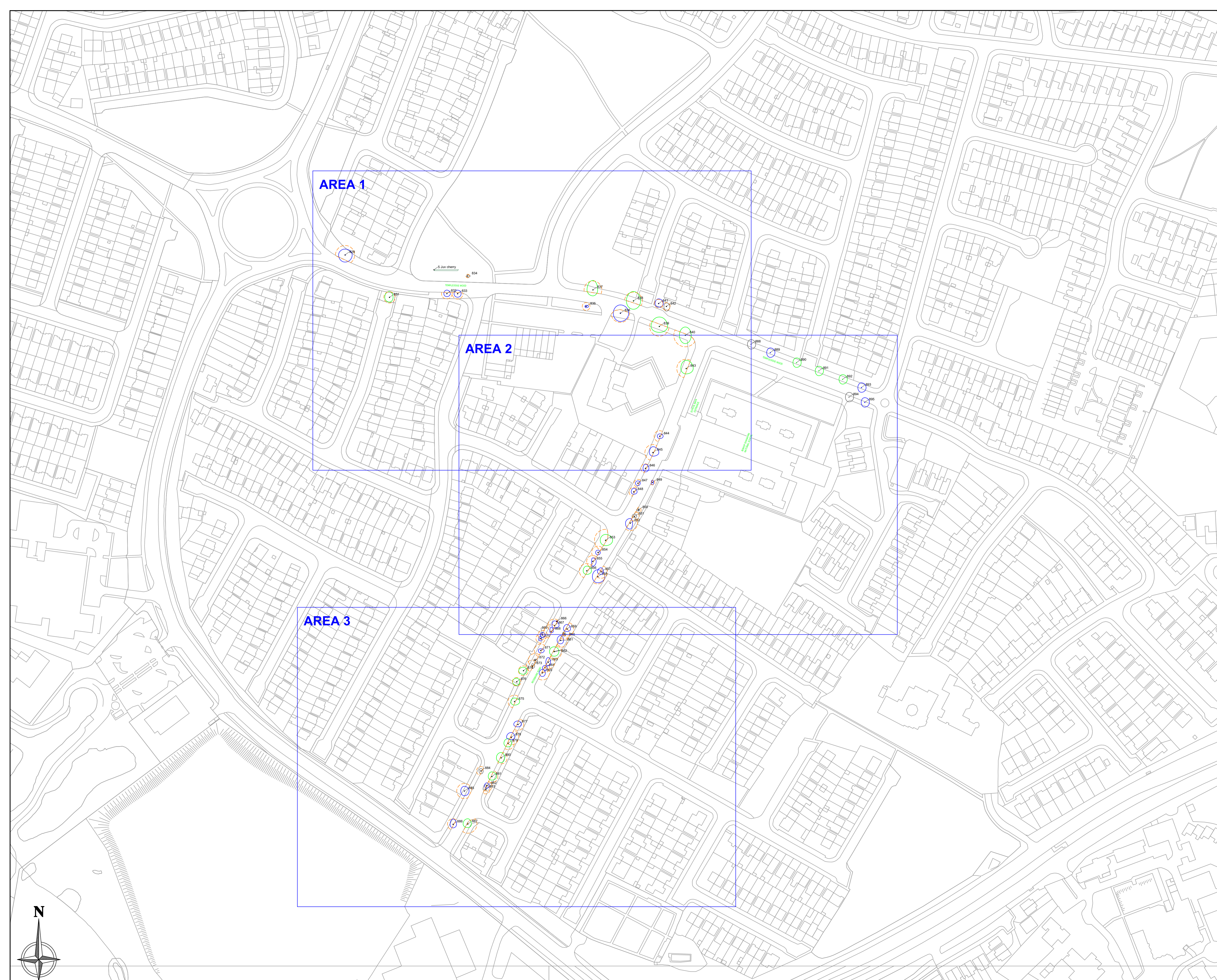

CLIENT



ENGINEERS



LEGEND

- TREE CONDITION CATEGORIES**
- A TREES OF HIGH VALUE AND QUALITY
  - B TREES OF MODERATE VALUE AND QUALITY
  - C TREES OF LOW QUALITY AND VALUE
  - U TREES OF VERY LOW VALUE AND QUALITY TO BE REMOVED IN THE INTERESTS OF SOUND ARBORICULTURAL MANAGEMENT
- TREE CONSTRAINTS  
 --- SITE BOUNDARY

Drawing to be interpreted with reference to Tree Survey document refers to proximate position

Tree constraints shown are calculated from guidelines contained within BS5837 (2012) within dimensions contained within Section 8 of the Tree Survey document. This outline should not be interpreted as the exact extent of root spread however it is considered the optimal area to be retained free of developmental impacts.

Natural and/or man made barriers such as waterlogged soil or buildings may restrict the spread of tree roots. Crown spreads may also prove to be a constraint particularly where crown reduction may not be possible.

The constraints lines shown on this drawing are therefore a guide only. An on-site assessment should be undertaken in the event of any developments being planned within the areas shown for retained trees.

REVISIONS

REV	DATE	DESCRIPTION

PROJECT: Limekiln Rd/Templeogue Wood Road/Rossmore Road upgrade

JOB NO: TWEL002

DRAWING: ARBORICULTURAL ASSESSMENT (KEYPLAN)

DATE: 31-08-22

SCALE: as shown @ A1

DRAWN BY: NIALL MCBRIDE

NMB INITIALS

STATUS: PLANNING

DRAWING NO. 105

REVISION: A

NOTES  
 Do Not Scale: Use Figured Dimensions Only  
 Not for Construction: Purpose unless Specifically Marked  
 © THIS DRAWING IS COPYRIGHT OF CMK HORTICULTURE + ARBORICULTURE LTD.



CLIENT



ENGINEERS



LEGEND

- TREE CONDITION CATEGORIES**
- A TREES OF HIGH VALUE AND QUALITY
  - B TREES OF MODERATE VALUE AND QUALITY
  - C TREES OF LOW QUALITY AND VALUE
  - U TREES OF VERY LOW VALUE AND QUALITY TO BE REMOVED IN THE INTERESTS OF SOUND ARBORICULTURAL MANAGEMENT

- TREE CONSTRAINTS
- SITE BOUNDARY

Drawing to be interpreted with reference to Tree Survey document refers to proximate position

Tree constraints shown are calculated from guidelines contained within BS5837 (2012) within dimensions contained within Section 8 of the Tree Survey document. This outline should not be interpreted as the exact extent of root spread however it is considered the optimal area to be retained free of developmental impacts. Natural and/or man made barriers such as waterlogged soil or buildings may restrict the spread of tree roots. Crown spreads may also prove to be a constraint particularly where crown reduction may not be possible. The constraints lines shown on this drawing are therefore a guide only. An on-site assessment should be undertaken in the event of any developments being planned within the areas shown for retained trees.



REVISIONS

REV	DATE	DESCRIPTION

PROJECT: LIMEKILN RD/TEMPLEOGUE WOOD ROAD/ROSSMORE ROAD UPGRADE      JOB NO. TWEL002

DRAWING: ARBORICULTURAL ASSESSMENT (1of3)      DATE: 31-08-22      SCALE: 1:425@ A1

DRAWN BY: NIALL MCBRIDE      NMB INITIALS

STATUS: PLANNING      REVISION: A

DRAWING NO. 106

NOTES  
Do Not Scale. Use Figured Dimensions Only.  
Not for Construction. Purpose unless Specifically Marked.  
© THIS DRAWING IS COPYRIGHT OF CMK HORTICULTURE + ARBORICULTURE LTD.

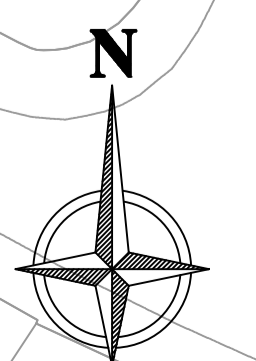
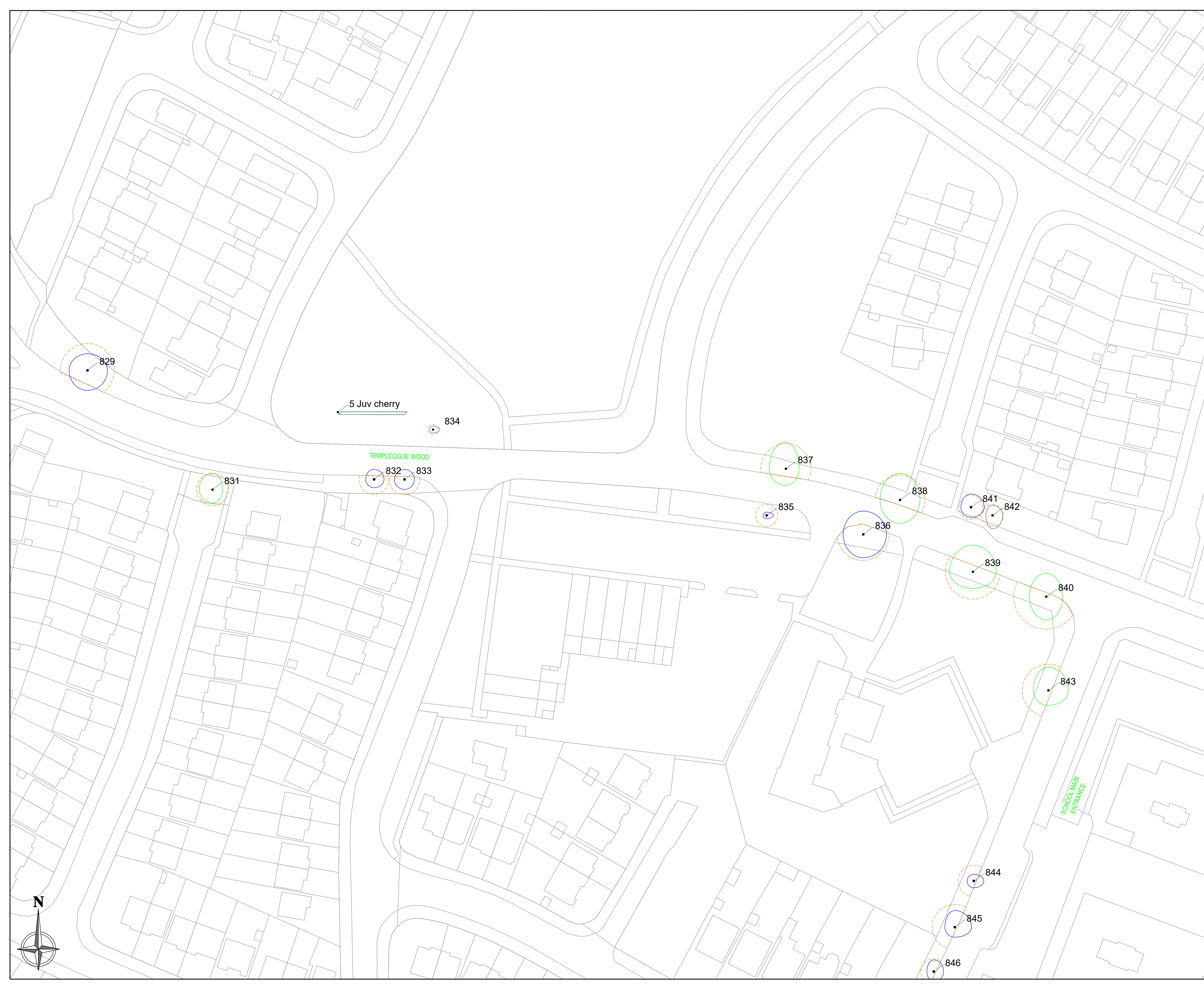



- TREE CONDITION CATEGORIES**
- A TREES OF HIGH VALUE AND QUALITY
  - B TREES OF MODERATE VALUE AND QUALITY
  - C TREES OF LOW QUALITY AND VALUE
  - U TREES OF VERY LOW VALUE AND QUALITY TO BE REMOVED IN THE INTERESTS OF SOUND ARBORICULTURAL MANAGEMENT
- TREE CONSTRAINTS  
 SITE BOUNDARY

Drawing to be interpreted with reference to Tree Survey document refers to proximate position

Tree constraints shown are calculated from guidelines contained within BS5837 (2012) with dimensions contained within Section 8 of the Tree Survey document. This outline should not be interpreted as the exact extent of root spread however it is considered the optimal area to be retained free of developmental impacts. Natural and/or man made barriers such as waterlogged soil or buildings may restrict the spread of tree roots. Crown spreads may also prove to be a constraint particularly where crown reduction may not be possible. The constraints lines shown on this drawing are therefore a guide only. An on-site assessment should be undertaken in the event of any developments being planned within the areas shown for retained trees.



REVISIONS

REV	DATE	DESCRIPTION

PROJECT: LIMEKILN RD/TEMPLEOGUE WOOD ROAD/ROSSMORE ROAD UPGRADE	JOB NO. TWEL002
--	--------------------

DRAWING: ARBORICULTURAL ASSESSMENT (2of3)	DATE: 31-08-22	SCALE: 1:425@ A1
--	-------------------	---------------------

DRAWN BY: NIALI MCBRIDE	NMB INITIALS
-------------------------	--------------

STATUS: PLANNING	REVISION: A
------------------	----------------

DRAWING NO. 107

NOTES  
Do Not Scale. Use Figured Dimensions Only.  
Not for Construction Purposes unless Specifically Marked.  
© THIS DRAWING IS COPYRIGHT OF CMK HORTICULTURE + ARBORICULTURE LTD.

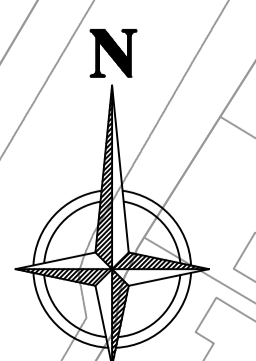
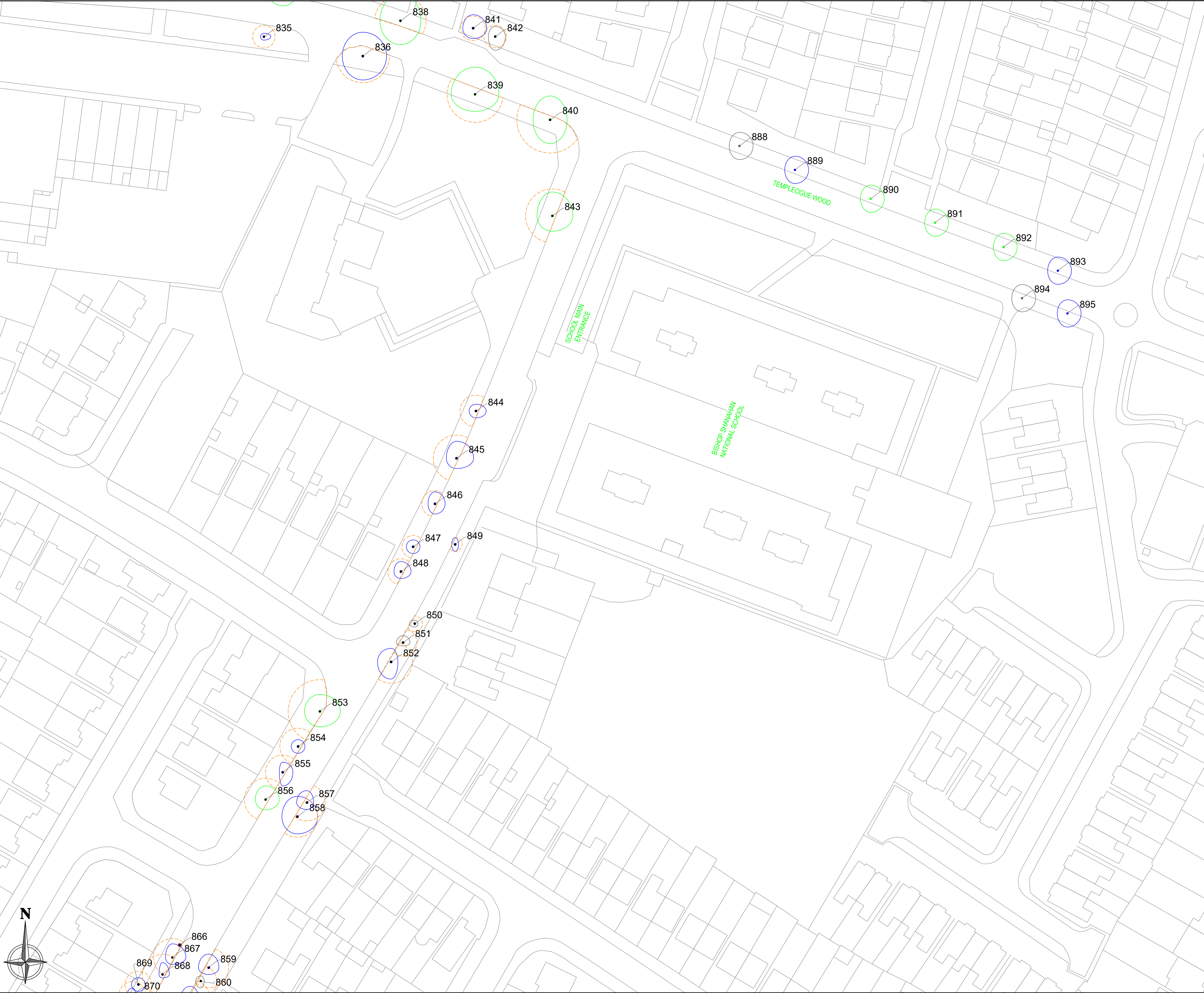

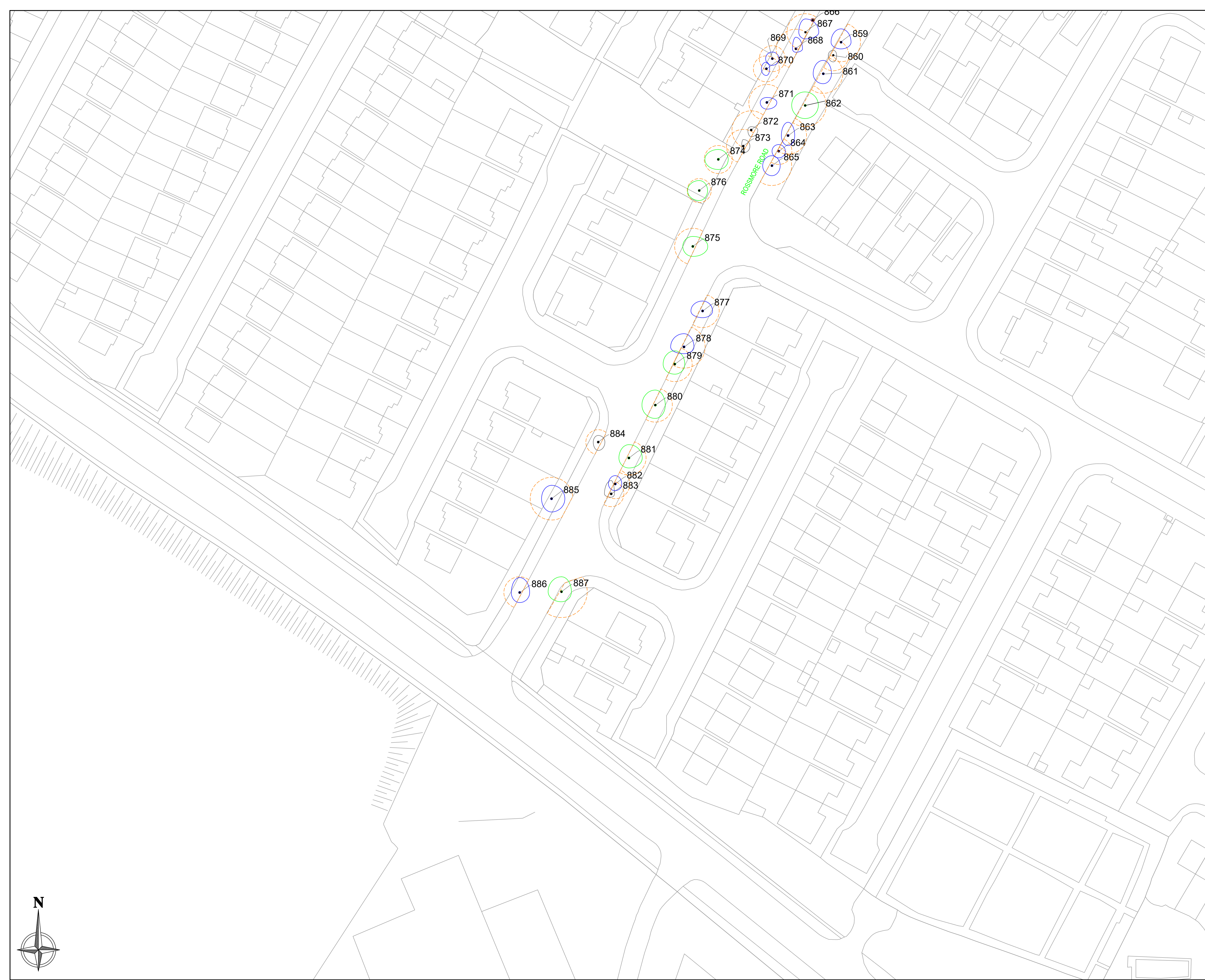

CLIENT  
 Corinnairie Corrae  
 Altra Cluith Theas  
 South Dublin County Council

ENGINEERS

LEGEND  
**TREE CONDITION CATEGORIES**  
 A TREES OF HIGH VALUE AND QUALITY  
 B TREES OF MODERATE VALUE AND QUALITY  
 C TREES OF LOW QUALITY AND VALUE  
 U TREES OF VERY LOW VALUE AND QUALITY TO BE REMOVED IN THE INTERESTS OF SOUND ARBORICULTURAL MANAGEMENT  
 TREE CONSTRAINTS  
 SITE BOUNDARY

Drawing to be interpreted with reference to Tree Survey document refers to proximate position  
 Tree constraints shown are calculated from guidelines contained within BS5837 (2012) within dimensions contained within Section 8 of the Tree Survey document. This outline should not be interpreted as the exact extent of root spread however it is considered the optimal area to be retained free of developmental impacts.  
 Natural and/or man made barriers such as waterlogged soil or buildings may restrict the spread of tree roots. Crown spreads may also prove to be a constraint particularly where crown reduction may not be possible.  
 The constraints lines shown on this drawing are therefore a guide only. An on-site assessment should be undertaken in the event of any developments being planned within the areas shown for retained trees.



REVISIONS

REV	DATE	DESCRIPTION

PROJECT: LIMEKILN RD/TEMPLEGGUE WOOD ROAD/ROSSMORE ROAD UPGRADE		JOB NO. TWEL002
DRAWING: ARBORICULTURAL ASSESSMENT (3of3)	DATE: 31-08-22	SCALE: 1:425@ A1
DRAWN BY: NIALL MCBRIDE		NMB INITIALS
STATUS: PLANNING		REVISION: A
DRAWING NO. 108		

NOTES  
 Do Not Scale. Use Figure Dimensions Only.  
 Not for Construction. Purpose unless Specifically Marked.  
 © THIS DRAWING IS COPYRIGHT OF CMK HORTICULTURE + ARBORICULTURE LTD.

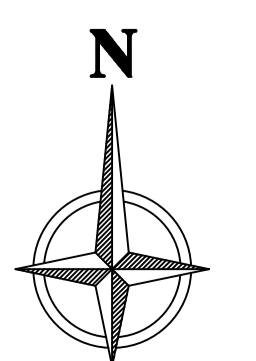

**CMK**  
 Hort & Arb Ltd.



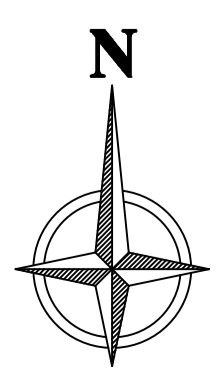
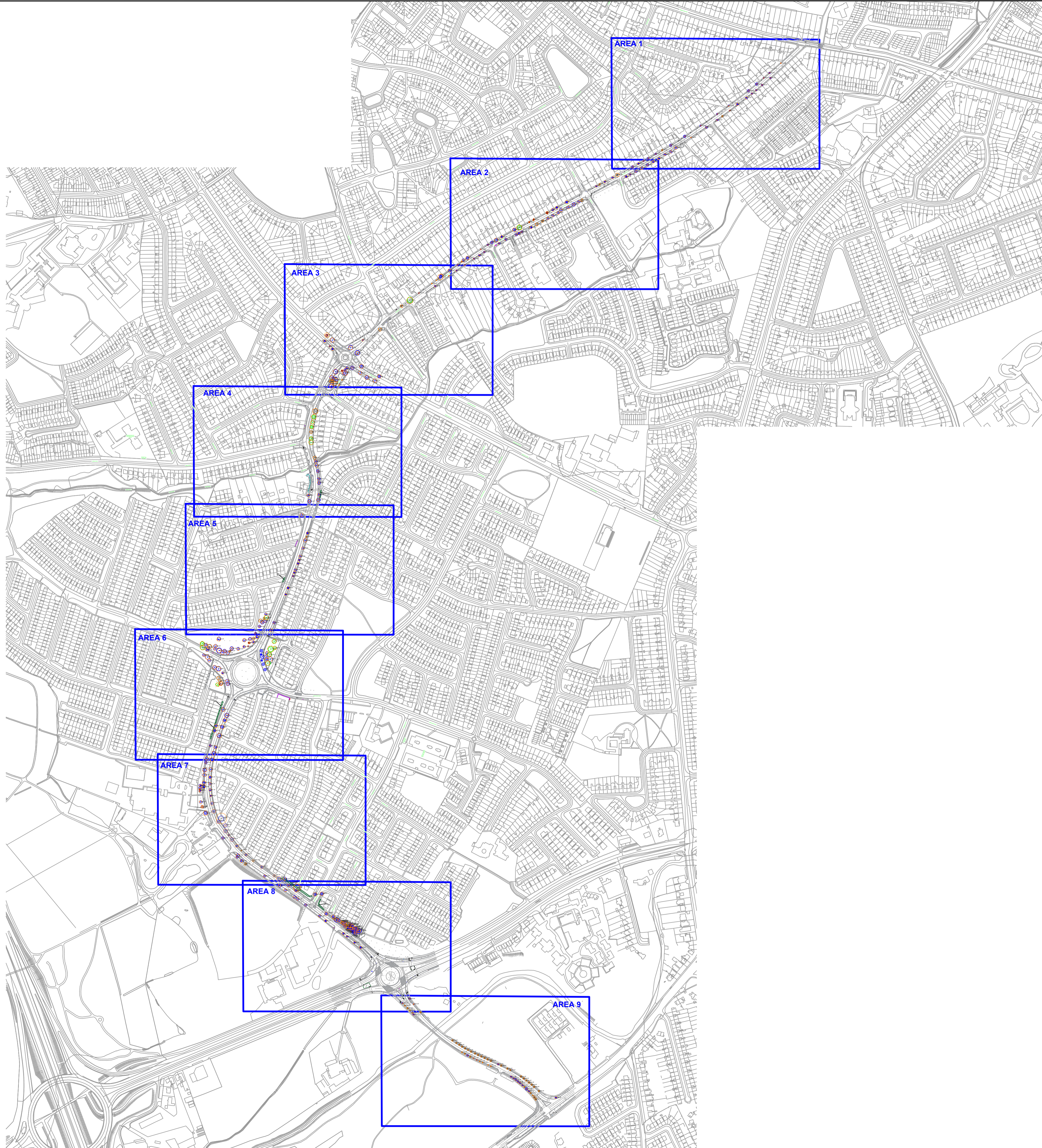

CLIENT



ENGINEERS



LEGEND

TREE CONDITION CATEGORIES

- A TREES OF HIGH VALUE AND QUALITY
- B TREES OF MODERATE VALUE AND QUALITY
- C TREES OF LOW QUALITY AND VALUE
- U TREES OF VERY LOW VALUE AND QUALITY TO BE REMOVED IN THE INTERESTS OF SOUND ARBORICULTURAL MANAGEMENT

- TREE CONSTRAINTS
- SITE BOUNDARY

Drawing to be interpreted with reference to Tree Survey document

Tree constraints shown are calculated from guidelines contained within BS5837 (2012) within dimensions contained within Section 8 of the Tree Survey document. This outline should not be interpreted as the exact extent of root spread however it is considered the optimal area to be retained free of developmental impacts.

Natural and/or man made barriers such as waterlogged soil or buildings may restrict the spread of tree roots. Crown spreads may also prove to be a constraint particularly where crown reduction may not be possible. The constraints lines shown on this drawing are therefore a guide only. An on-site assessment should be undertaken in the event of any developments being planned within the areas shown for retained trees.

REVISIONS

REV	DATE	DESCRIPTION

PROJECT: WHITEHALL RD/WELLINGTON ROAD/WELLINGTON LANE ROAD UPGRADE		JOB NO. TWEL002
DRAWING: ARBORICULTURAL ASSESSMENT (KEYPLAN)	DATE: 17-11-21	SCALE: as shown @ A1
DRAWN BY: NIALL MCBRIDE		NMB INITIALS
STATUS: PLANNING		REVISION.
DRAWING NO. 109		

NOTES  
Do Not Scale. Use Figured Dimensions Only.  
Not for Construction. Purpose unless Specifically Marked.  
© THIS DRAWING IS COPYRIGHT OF CMK HORTICULTURE + ARBORICULTURE LTD.



# AREA 1

CLIENT



ENGINEERS



LEGEND

**TREE CONDITION CATEGORIES**

- A TREES OF HIGH VALUE AND QUALITY
- B TREES OF MODERATE VALUE AND QUALITY
- C TREES OF LOW QUALITY AND VALUE
- U TREES OF VERY LOW VALUE AND QUALITY TO BE REMOVED IN THE INTERESTS OF SOUND ARBORICULTURAL MANAGEMENT

- TREE CONSTRAINTS
- SITE BOUNDARY

Drawing to be interpreted with reference to Tree Survey document  
 Tree constraints shown are calculated from guidelines contained within BS5837 (2012) within dimensions contained within Section 8 of the Tree Survey document. This outline should not be interpreted as the exact extent of root spread however it is considered the optimal area to be retained free of developmental impacts.  
 Natural and/or man made barriers such as waterlogged soil or buildings may restrict the spread of tree roots. Crown spreads may also prove to be a constraint particularly where crown reduction may not be possible.  
 The constraints lines shown on this drawing are therefore a guide only. An on-site assessment should be undertaken in the event of any developments being planned within the areas shown for retained trees.

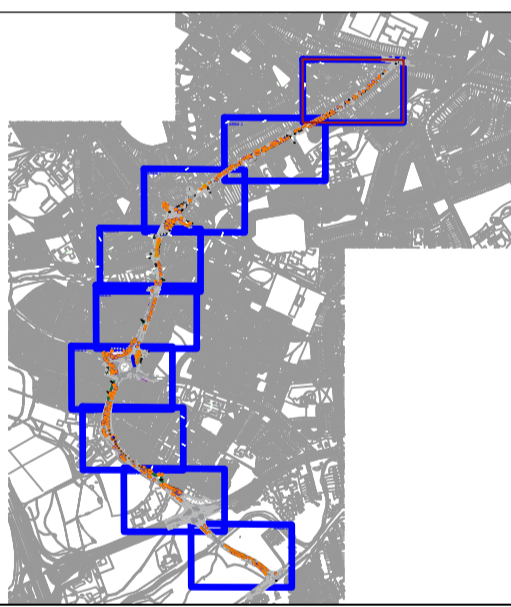

REVISIONS

REV	DATE	DESCRIPTION

PROJECT: WHITEHALL RD/WELLINGTON ROAD/WELLINGTON LANE ROAD UPGRADE		JOB NO. TWEL002
DRAWING: ARBORICULTURAL ASSESSMENT (1 of 9)	DATE: 17-11-21	SCALE: 1:425@ A1
DRAWN BY: NIALL MCBRIDE		NMB INITIALS
STATUS: PLANNING		REVISION:
DRAWING NO. 110		

NOTES  
 Do Not Scale: Use Figure Dimensions Only.  
 Not for Construction: Purpose unless Specifically Marked.  
 © THIS DRAWING IS COPYRIGHT OF CMK HORTICULTURE + ARBORICULTURE LTD.

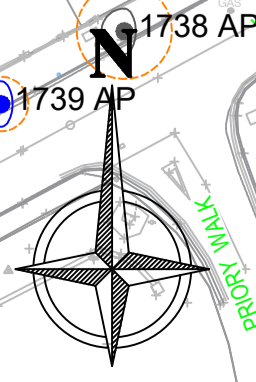
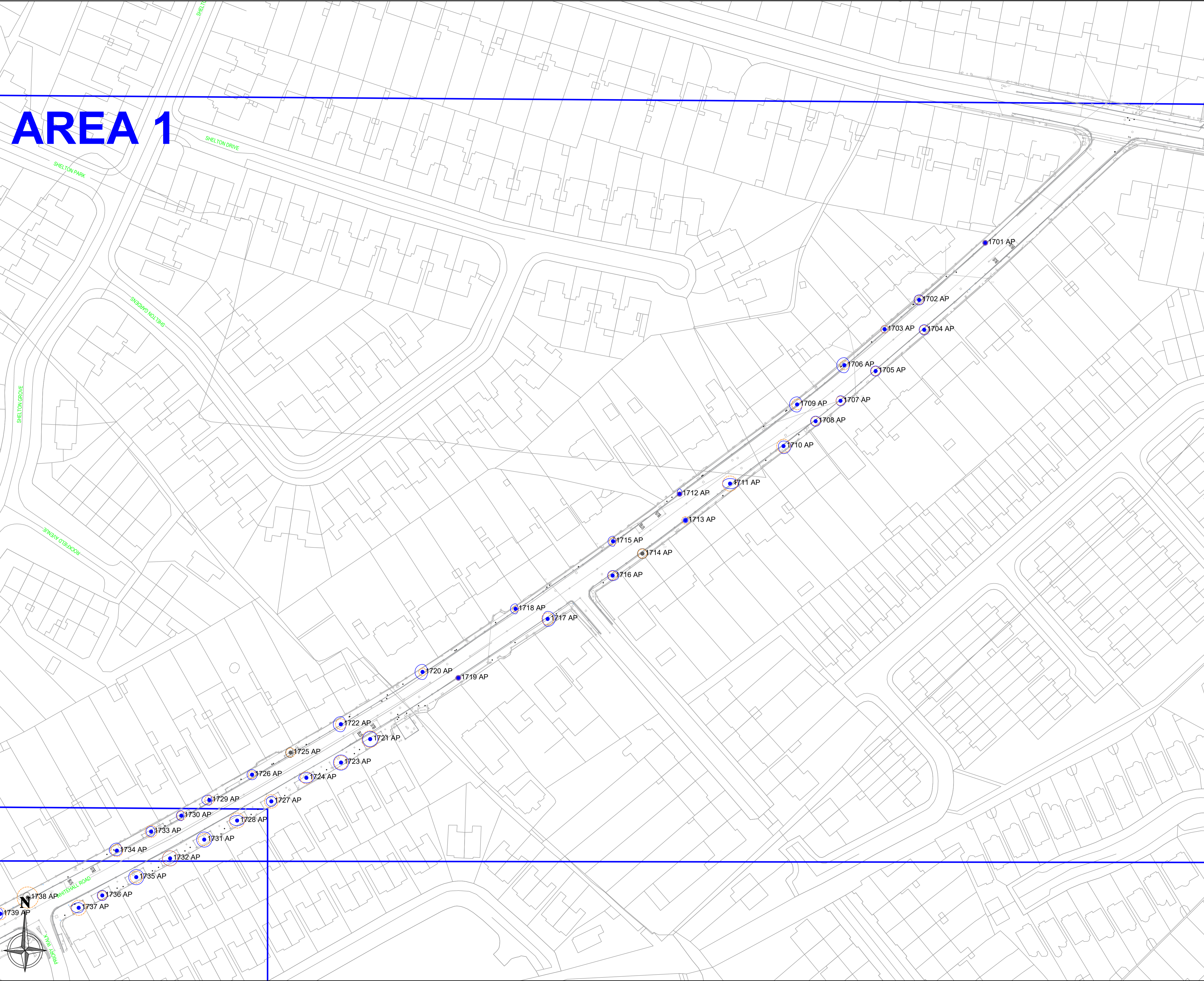

# AREA 2

CLIENT



ENGINEERS



LEGEND

**TREE CONDITION CATEGORIES**

- A TREES OF HIGH VALUE AND QUALITY
- B TREES OF MODERATE VALUE AND QUALITY
- C TREES OF LOW QUALITY AND VALUE
- U TREES OF VERY LOW VALUE AND QUALITY TO BE REMOVED IN THE INTERESTS OF SOUND ARBORICULTURAL MANAGEMENT

- TREE CONSTRAINTS
- SITE BOUNDARY

Drawing to be interpreted with reference to Tree Survey document  
 Tree constraints shown are calculated from guidelines contained within BS5837 (2012) within dimensions contained within Section 8 of the Tree Survey document. This outline should not be interpreted as the exact extent of root spread however it is considered the optimal area to be retained free of developmental impacts.  
 Natural and/or man made barriers such as waterlogged soil or buildings may restrict the spread of tree roots. Crown spreads may also prove to be a constraint particularly where crown reduction may not be possible. The constraints lines shown on this drawing are therefore a guide only. An on-site assessment should be undertaken in the event of any developments being planned within the areas shown for retained trees.

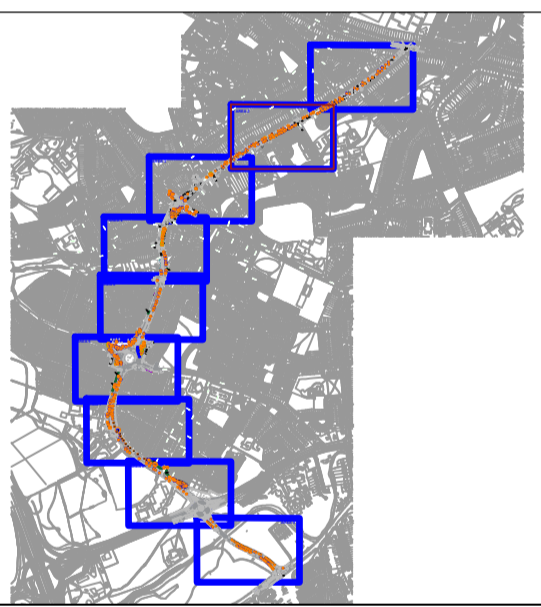

REVISIONS

REV	DATE	DESCRIPTION

PROJECT: WHITEHALL RD/WELLINGTON ROAD/WELLINGTON LANE ROAD UPGRADE		JOB NO. TWEL002
DRAWING: ARBORICULTURAL ASSESSMENT (2of9)	DATE: 17-11-21	SCALE: 1:425@ A1
DRAWN BY: NIALL MCBRIDE		NMB INITIALS
STATUS: PLANNING		REVISION:
DRAWING NO. 111		

**NOTES**  
 Do Not Scale. Use Figured Dimensions Only.  
 Not for Construction. Purpose unless Specifically Marked.  
 © THIS DRAWING IS COPYRIGHT OF CMK HORTICULTURE + ARBORICULTURE LTD.

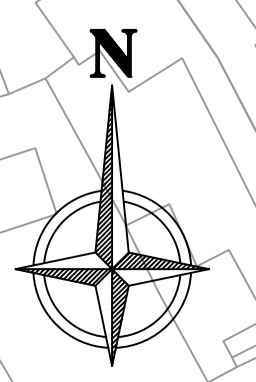

# AREA 3

CLIENT



ENGINEERS



LEGEND

**TREE CONDITION CATEGORIES**

- A TREES OF HIGH VALUE AND QUALITY
- B TREES OF MODERATE VALUE AND QUALITY
- C TREES OF LOW QUALITY AND VALUE
- U TREES OF VERY LOW VALUE AND QUALITY TO BE REMOVED IN THE INTERESTS OF SOUND ARBORICULTURAL MANAGEMENT

- TREE CONSTRAINTS
- SITE BOUNDARY

Drawing to be interpreted with reference to Tree Survey document  
 Tree constraints shown are calculated from guidelines contained within BS5837 (2012) within dimensions contained within Section 8 of the Tree Survey document. This outline should not be interpreted as the exact extent of root spread however it is considered the optimal area to be retained free of developmental impacts.  
 Natural and/or man made barriers such as waterlogged soil or buildings may restrict the spread of tree roots. Crown spreads may also prove to be a constraint particularly where crown reduction may not be possible.  
 The constraints lines shown on this drawing are therefore a guide only. An on-site assessment should be undertaken in the event of any developments being planned within the areas shown for retained trees.



REVISIONS

REV	DATE	DESCRIPTION

PROJECT: WHITEHALL RD/WELLINGTON ROAD/WELLINGTON LANE ROAD UPGRADE		JOB NO. TWEL002
DRAWING: ARBORICULTURAL ASSESSMENT (3of9)	DATE: 17-11-21	SCALE: 1:425@ A1
DRAWN BY: NIALL MCBRIDE		NMB INITIALS
STATUS: PLANNING		REVISION:
DRAWING NO. 112		

NOTES  
 Do Not Scale: Use Figure Dimensions Only.  
 Not for Construction: Purpose unless Specifically Marked.  
 © THIS DRAWING IS COPYRIGHT OF CMK HORTICULTURE + ARBORICULTURE LTD.

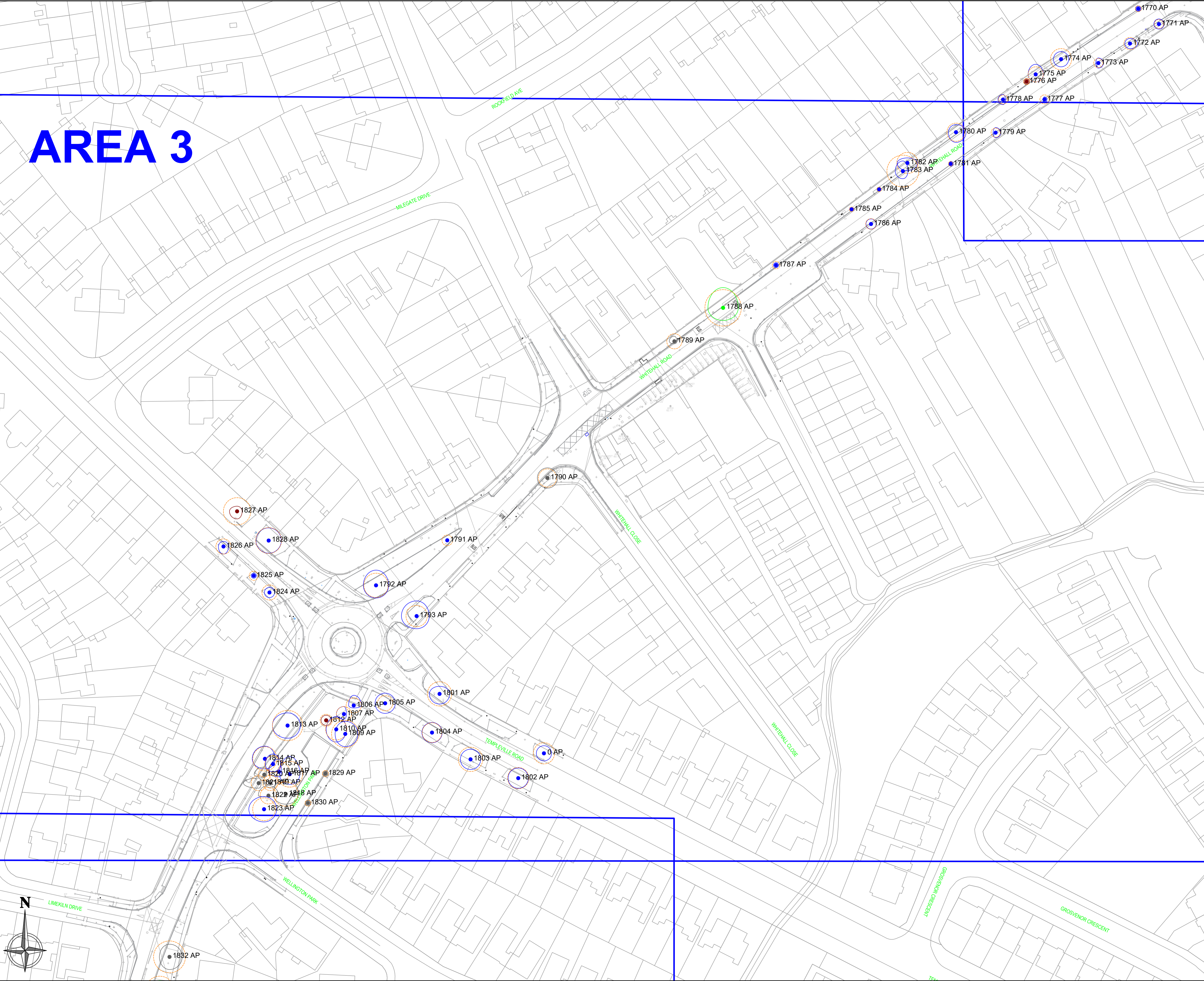
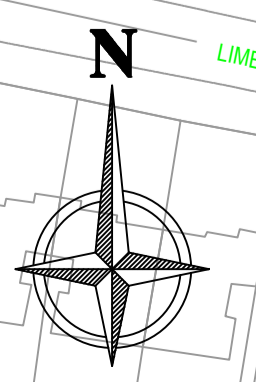

# AREA 4

CLIENT



ENGINEERS



LEGEND

**TREE CONDITION CATEGORIES**

- A TREES OF HIGH VALUE AND QUALITY
- B TREES OF MODERATE VALUE AND QUALITY
- C TREES OF LOW QUALITY AND VALUE
- U TREES OF VERY LOW VALUE AND QUALITY TO BE REMOVED IN THE INTERESTS OF SOUND ARBORICULTURAL MANAGEMENT

- TREE CONSTRAINTS
- SITE BOUNDARY

Drawing to be interpreted with reference to Tree Survey document  
 Tree constraints shown are calculated from guidelines contained within BS5837 (2012) within dimensions contained within Section 8 of the Tree Survey document. This outline should not be interpreted as the exact extent of root spread however it is considered the optimal area to be retained free of developmental impacts.  
 Natural and/or man made barriers such as waterlogged soil or buildings may restrict the spread of tree roots. Crown spreads may also prove to be a constraint particularly where crown reduction may not be possible. The constraints lines shown on this drawing are therefore a guide only. An on-site assessment should be undertaken in the event of any developments being planned within the areas shown for retained trees.



REVISIONS

REV	DATE	DESCRIPTION

PROJECT: WHITEHALL RD/WELLINGTON ROAD/WELLINGTON LANE ROAD UPGRADE		JOB NO. TWEL002
DRAWING: ARBORICULTURAL ASSESSMENT (4of9)	DATE: 17-11-21	SCALE: 1:425@ A1
DRAWN BY: NIALL MCBRIDE		NMB INITIALS
STATUS: PLANNING		REVISION:
DRAWING NO. 113		

NOTES  
 Do Not Scale. Use Figure Dimensions Only.  
 Not for Construction Purpose unless Specifically Marked.  
 © THIS DRAWING IS COPYRIGHT OF CMK HORTICULTURE + ARBORICULTURE LTD.



# AREA 5

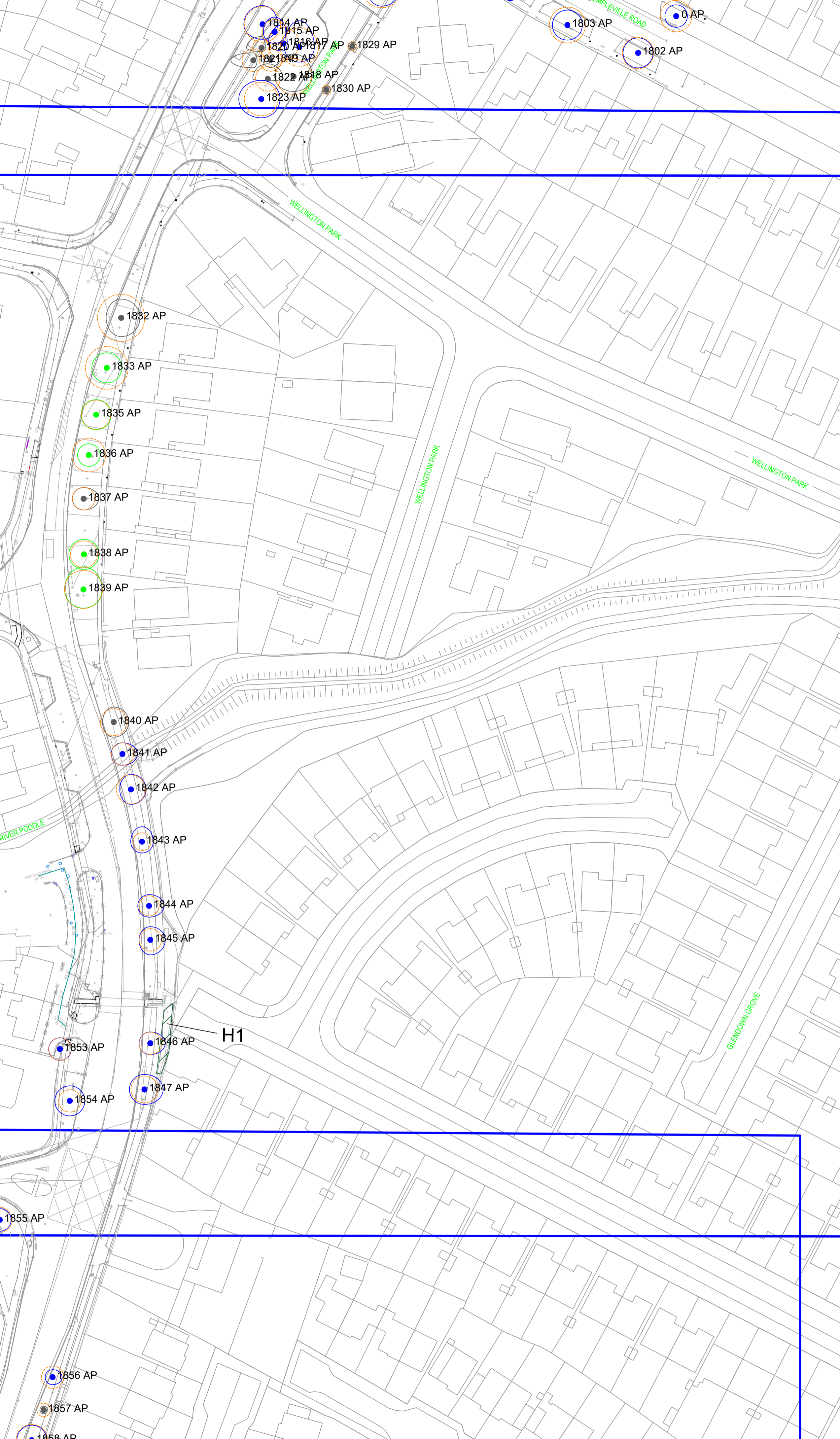
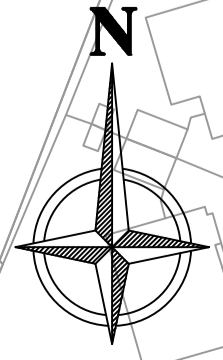

# AREA 5

CLIENT



ENGINEERS



LEGEND

- TREE CONDITION CATEGORIES**
- A TREES OF HIGH VALUE AND QUALITY
  - B TREES OF MODERATE VALUE AND QUALITY
  - C TREES OF LOW QUALITY AND VALUE
  - U TREES OF VERY LOW VALUE AND QUALITY TO BE REMOVED IN THE INTERESTS OF SOUND ARBORICULTURAL MANAGEMENT

- TREE CONSTRAINTS
- SITE BOUNDARY

Drawing to be interpreted with reference to Tree Survey document

Tree constraints shown are calculated from guidelines contained within BS5837 (2012) within dimensions contained within Section 8 of the Tree Survey document. This outline should not be interpreted as the exact extent of root spread however it is considered the optimal area to be retained free of developmental impacts.

Natural and/or man made barriers such as waterlogged soil or buildings may restrict the spread of tree roots. Crown spreads may also prove to be a constraint particularly where crown reduction may not be possible. The constraints lines shown on this drawing are therefore a guide only. An on-site assessment should be undertaken in the event of any developments being planned within the areas shown for retained trees.

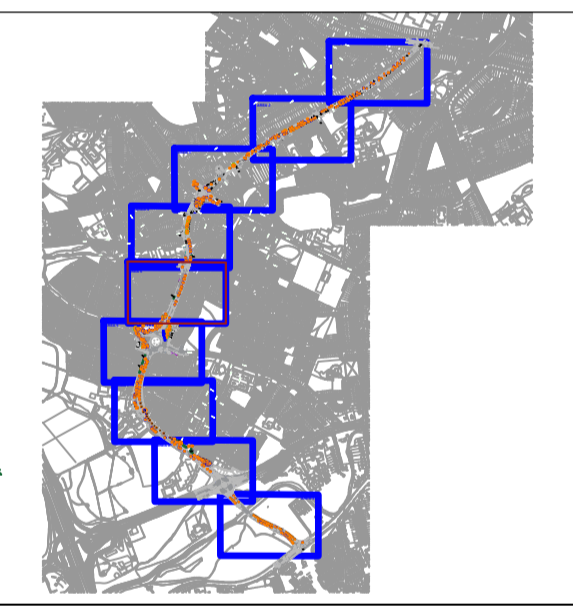

REVISIONS

REV	DATE	DESCRIPTION

PROJECT:	WHITEHALL RD/WELLINGTON ROAD/WELLINGTON LANE ROAD UPGRADE	JOB NO.:	TWEL002
DRAWING:	ARBORICULTURAL ASSESSMENT (5of9)	DATE:	17-11-21
DRAWN BY:	NIALL MCBRIDE	SCALE:	1:425@ A1
STATUS:	PLANNING	NMB INITIALS	
DRAWING NO.:	114	REVISION:	

NOTES

Do Not Scale. Use Figured Dimensions Only.

Not for Construction Purposes unless Specifically Marked.

© THIS DRAWING IS COPYRIGHT OF CMK HORTICULTURE + ARBORICULTURE LTD.

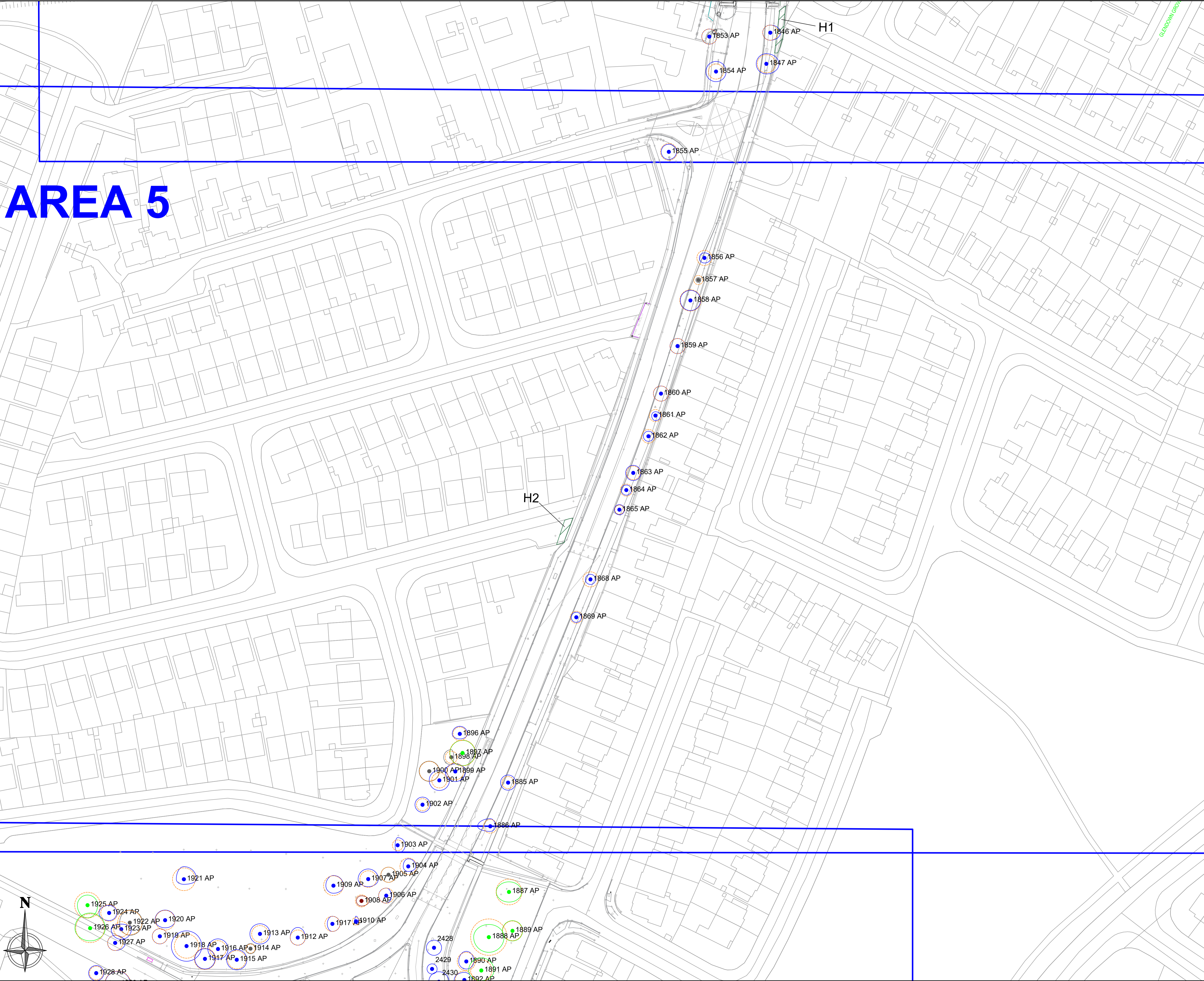
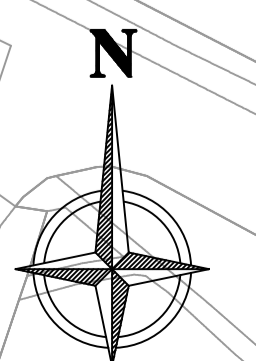



TREE CONDITION CATEGORIES

- A TREES OF HIGH VALUE AND QUALITY
- B TREES OF MODERATE VALUE AND QUALITY
- C TREES OF LOW QUALITY AND VALUE
- U TREES OF VERY LOW VALUE AND QUALITY TO BE REMOVED IN THE INTERESTS OF SOUND ARBORICULTURAL MANAGEMENT

- TREE CONSTRAINTS
- SITE BOUNDARY

Drawing to be interpreted with reference to Tree Survey document

Tree constraints shown are calculated from guidelines contained within BS5837 (2012) within dimensions contained within Section 8 of the Tree Survey document. This outline should not be interpreted as the exact extent of root spread however it is considered the optimal area to be retained free of developmental impacts.

Natural and/or man made barriers such as waterlogged soil or buildings may restrict the spread of tree roots. Crown spreads may also prove to be a constraint particularly where crown reduction may not be possible. The constraints lines shown on this drawing are therefore a guide only. An on-site assessment should be undertaken in the event of any developments being planned within the areas shown for retained trees.

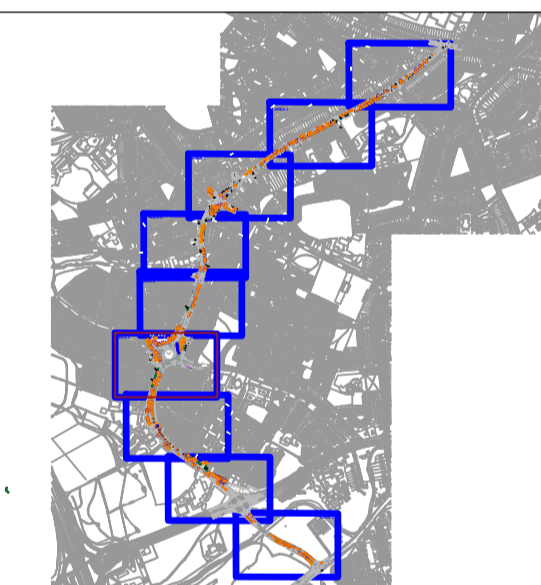

REVISIONS

REV	DATE	DESCRIPTION

PROJECT: WHITEHALL RD/WELLINGTON ROAD/WELLINGTON LANE ROAD UPGRADE		JOB NO. TWEL002
DRAWING: ARBORICULTURAL ASSESSMENT (6of9)	DATE: 17-11-21	SCALE: 1:425@ A1
DRAWN BY: NIALL MCBRIDE		NMB INITIALS
STATUS: PLANNING		REVISION:
DRAWING NO. 115		

NOTES  
Do Not Scale: Use Figure Dimensions Only.  
Not for Construction: Purpose unless Specifically Marked.

© THIS DRAWING IS COPYRIGHT OF CMK HORTICULTURE + ARBORICULTURE LTD.



# AREA 6

# AREA 7

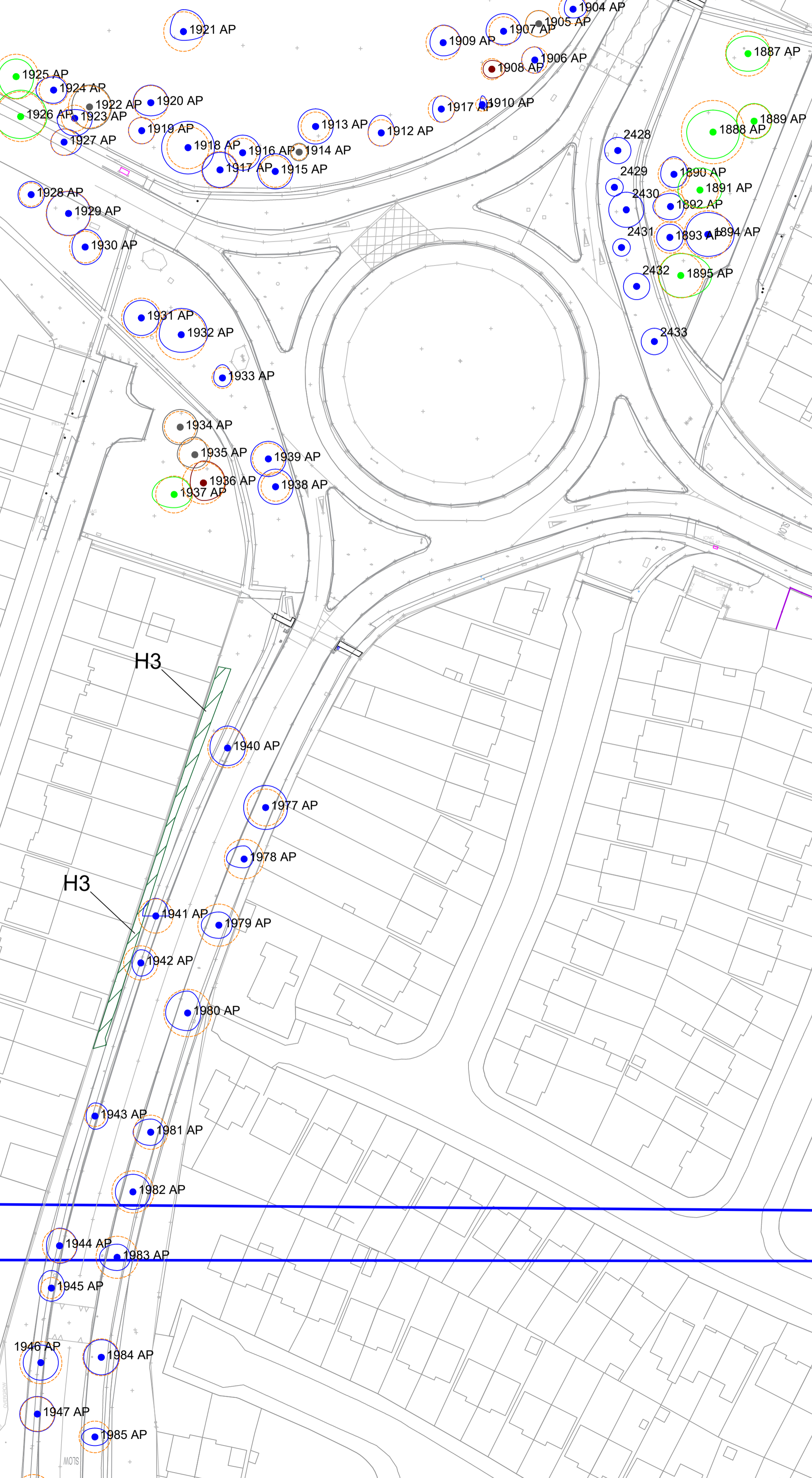
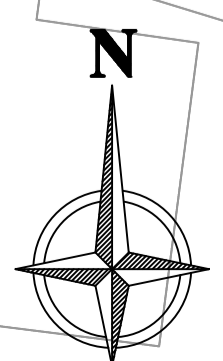

# AREA 7

# AREA 8

CLIENT



ENGINEERS



LEGEND

- TREE CONDITION CATEGORIES**
- A TREES OF HIGH VALUE AND QUALITY
  - B TREES OF MODERATE VALUE AND QUALITY
  - C TREES OF LOW QUALITY AND VALUE
  - U TREES OF VERY LOW VALUE AND QUALITY TO BE REMOVED IN THE INTERESTS OF SOUND ARBORICULTURAL MANAGEMENT

- TREE CONSTRAINTS
- SITE BOUNDARY

Drawing to be interpreted with reference to Tree Survey document  
 Tree constraints shown are calculated from guidelines contained within BS5837 (2012) within dimensions contained within Section 8 of the Tree Survey document. This outline should not be interpreted as the exact extent of root spread however it is considered the optimal area to be retained free of developmental impacts.  
 Natural and/or man made barriers such as waterlogged soil or buildings may restrict the spread of tree roots. Crown spreads may also prove to be a constraint particularly where crown reduction may not be possible.  
 The constraints lines shown on this drawing are therefore a guide only. An on-site assessment should be undertaken in the event of any developments being planned within the areas shown for retained trees.



REVISIONS

REV	DATE	DESCRIPTION

PROJECT: WHITEHALL RD/WELLINGTON ROAD/WELLINGTON LANE ROAD UPGRADE  
 JOB NO: TWEL002

DRAWING: ARBORICULTURAL ASSESSMENT (7of9)  
 DATE: 17-11-21  
 SCALE: 1:425@ A1

DRAWN BY: NIALL MCBRIDE  
 NMB INITIALS  
 STATUS: PLANNING  
 DRAWING NO. 116  
 REVISION:

NOTES  
 Do Not Scale: Use Figural Dimensions Only  
 Not for Construction: Purpose unless Specifically Marked  
 © THIS DRAWING IS COPYRIGHT OF CMK HORTICULTURE + ARBORICULTURE LTD.

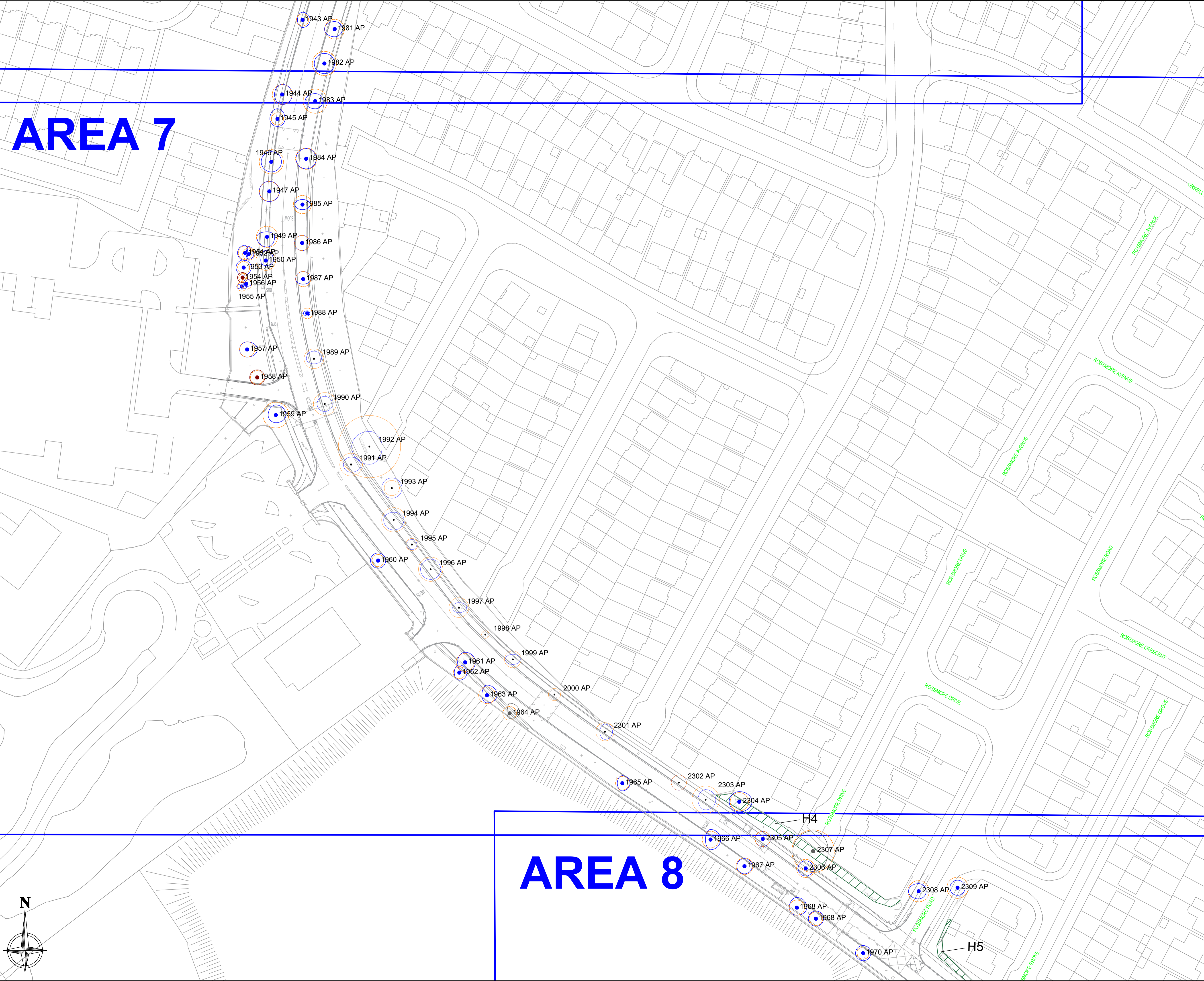
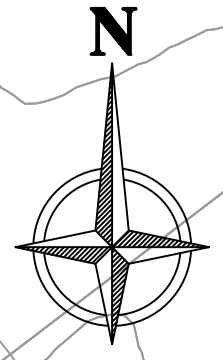



# AREA 8

CLIENT



ENGINEERS



LEGEND

- TREE CONDITION CATEGORIES**
- A TREES OF HIGH VALUE AND QUALITY
  - B TREES OF MODERATE VALUE AND QUALITY
  - C TREES OF LOW QUALITY AND VALUE
  - U TREES OF VERY LOW VALUE AND QUALITY TO BE REMOVED IN THE INTERESTS OF SOUND ARBORICULTURAL MANAGEMENT

- TREE CONSTRAINTS
- SITE BOUNDARY

Drawing to be interpreted with reference to Tree Survey document  
 Tree constraints shown are calculated from guidelines contained within BS5837:2012 (within dimensions contained within Section 8 of the Tree Survey document. This outline should not be interpreted as the exact extent of root spread however it is considered the optimal area to be retained free of developmental impacts.  
 Natural and/or man made barriers such as waterlogged soil or buildings may restrict the spread of tree roots. Crown spreads may also prove to be a constraint particularly where crown reduction may not be possible.  
 The constraints lines shown on this drawing are therefore a guide only. An on-site assessment should be undertaken in the event of any developments being planned within the areas shown for retained trees.



REVISIONS

REV	DATE	DESCRIPTION

PROJECT: WHITEHALL RD/WELLINGTON ROAD/WELLINGTON LANE ROAD UPGRADE

JOB NO. TWEL002

DRAWING: ARBORICULTURAL ASSESSMENT (8of9)

DATE: 17-11-21

SCALE: 1:425@ A1

DRAWN BY: NIALL MCBRIDE

NMB INITIALS

STATUS: PLANNING

REVISION:

DRAWING NO. 117

NOTES  
 Do Not Scale. Use Figure Dimensions Only.  
 Not for Construction. Purpose unless Specifically Marked.

© THIS DRAWING IS COPYRIGHT OF CMK HORTICULTURE + ARBORICULTURE LTD.

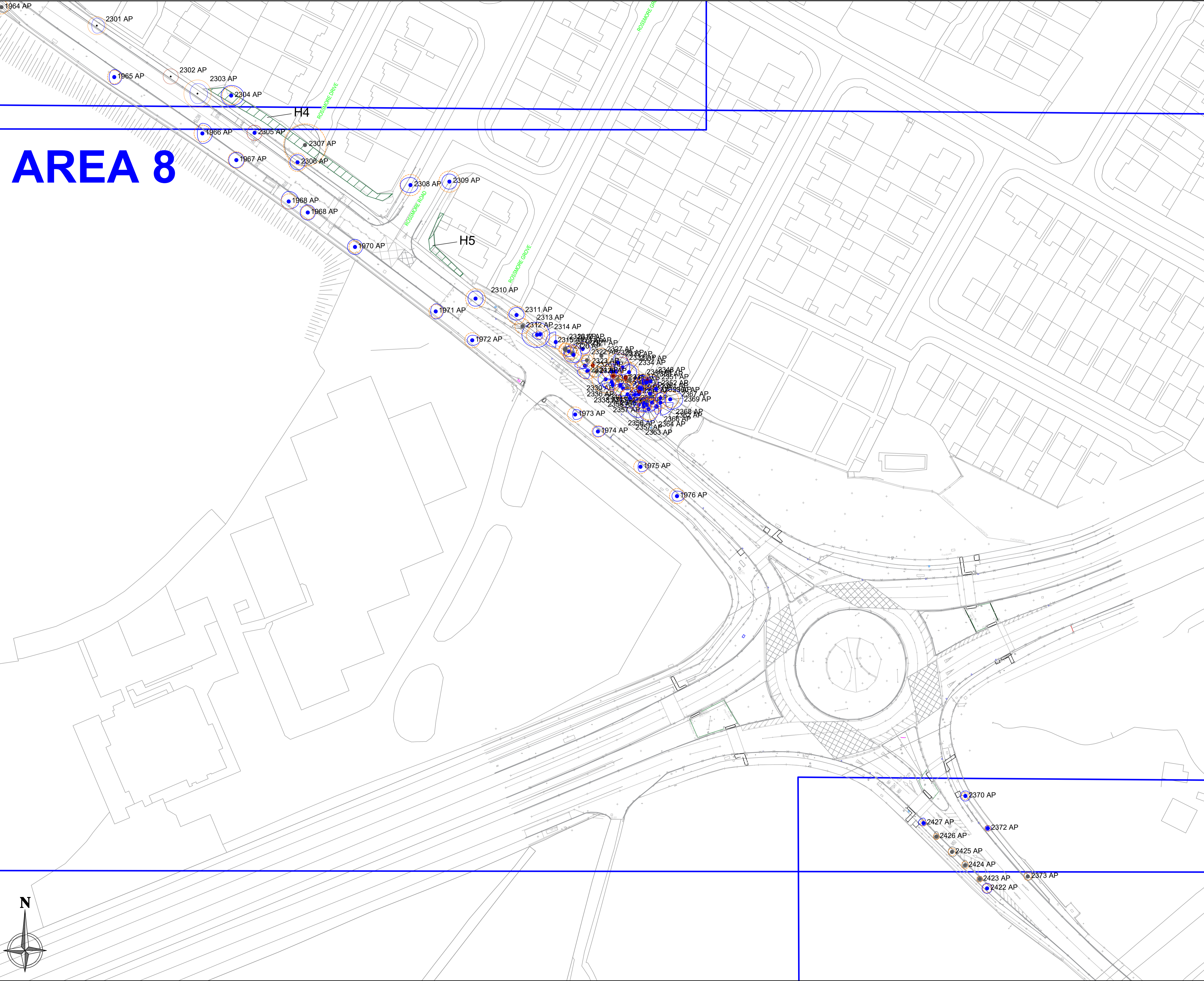
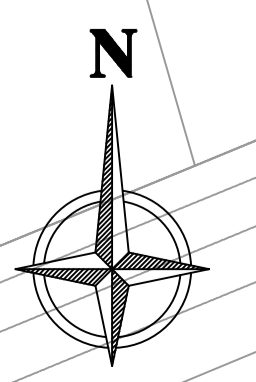



- TREE CONDITION CATEGORIES**
- A TREES OF HIGH VALUE AND QUALITY
  - B TREES OF MODERATE VALUE AND QUALITY
  - C TREES OF LOW QUALITY AND VALUE
  - U TREES OF VERY LOW VALUE AND QUALITY TO BE REMOVED IN THE INTERESTS OF SOUND ARBORICULTURAL MANAGEMENT

- TREE CONSTRAINTS
- SITE BOUNDARY

Drawing to be interpreted with reference to Tree Survey document

Tree constraints shown are calculated from guidelines contained within BS5837 (2012) within dimensions contained within Section 8 of the Tree Survey document. This outline should not be interpreted as the exact extent of root spread however it is considered the optimal area to be free of developmental impacts.

Natural and/or man made barriers such as waterlogged soil or buildings may restrict the spread of tree roots. Crown spreads may also prove to be a constraint particularly where crown reduction may not be possible.

The constraints lines shown on this drawing are therefore a guide only. An on-site assessment should be undertaken in the event of any developments being planned within the areas shown for retained trees.

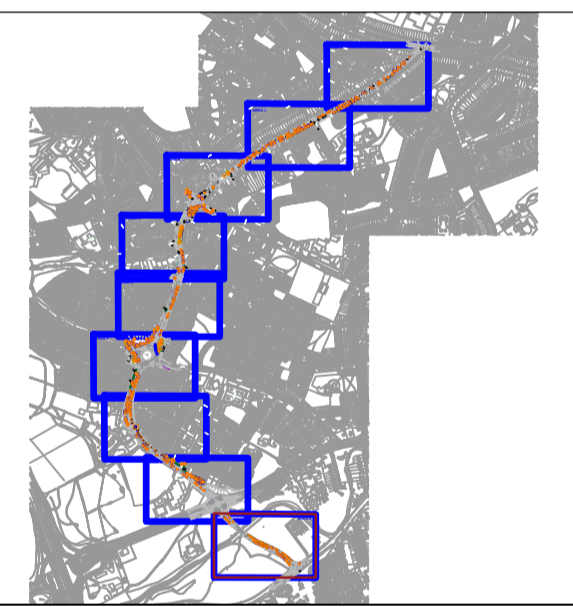

REVISIONS

REV	DATE	DESCRIPTION

PROJECT: WHITEHALL RD/WELLINGTON ROAD/WELLINGTON LANE ROAD UPGRADE

JOB NO: TWEL002

DRAWING: ARBORICULTURAL ASSESSMENT (90f9)

DATE: 17-11-21

SCALE: 1:425@ A1

DRAWN BY: NIALL MCBRIDE

NMB INITIALS

STATUS: PLANNING

REVISION:

DRAWING NO. 118

**NOTES**  
Do Not Scale: Use Figured Dimensions Only  
Not for Construction: Purpose unless Specifically Marked  
© THIS DRAWING IS COPYRIGHT OF CMK HORTICULTURE + ARBORICULTURE LTD.

# AREA 9

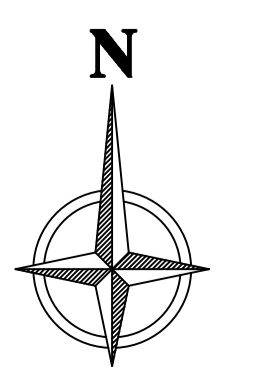
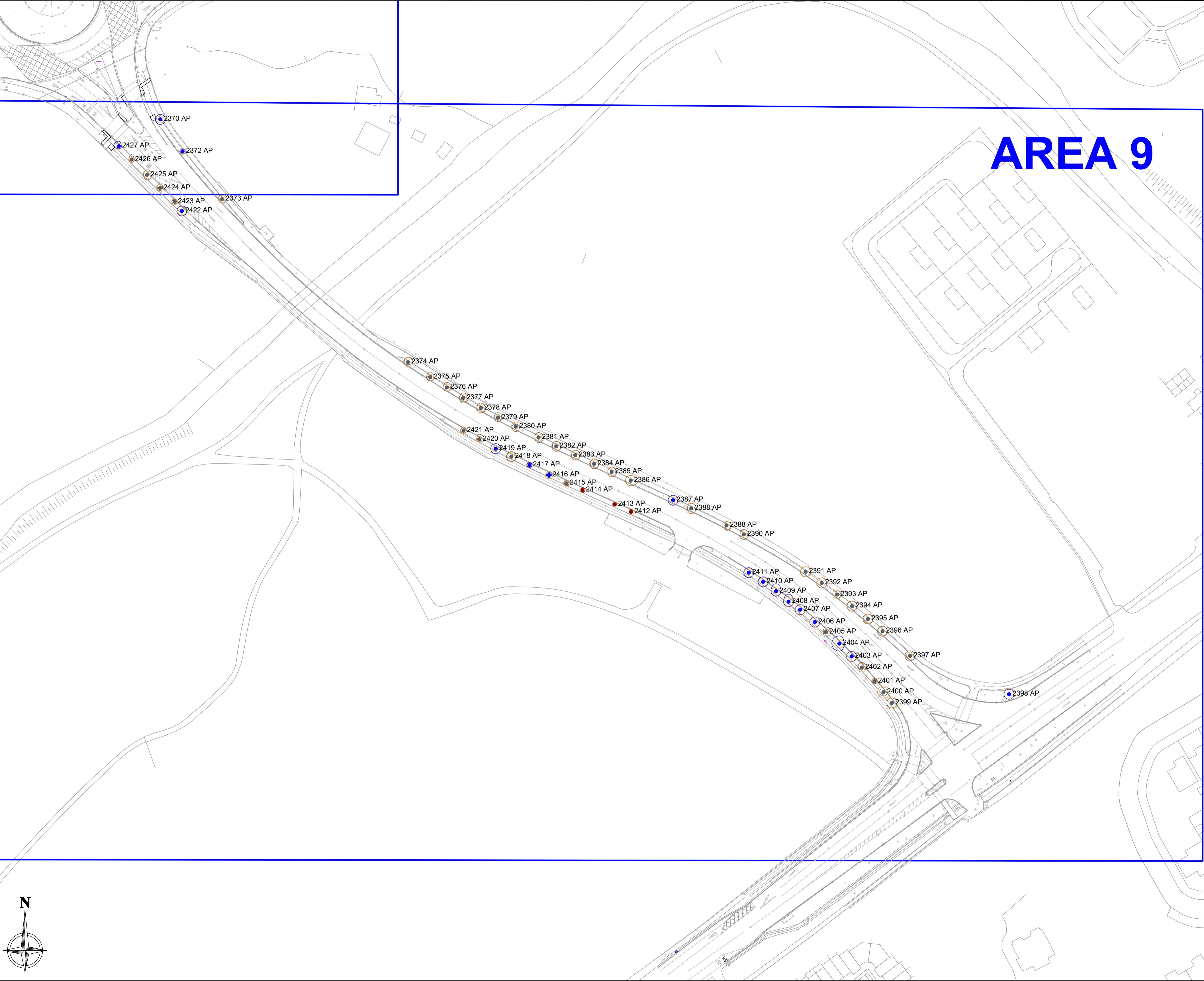

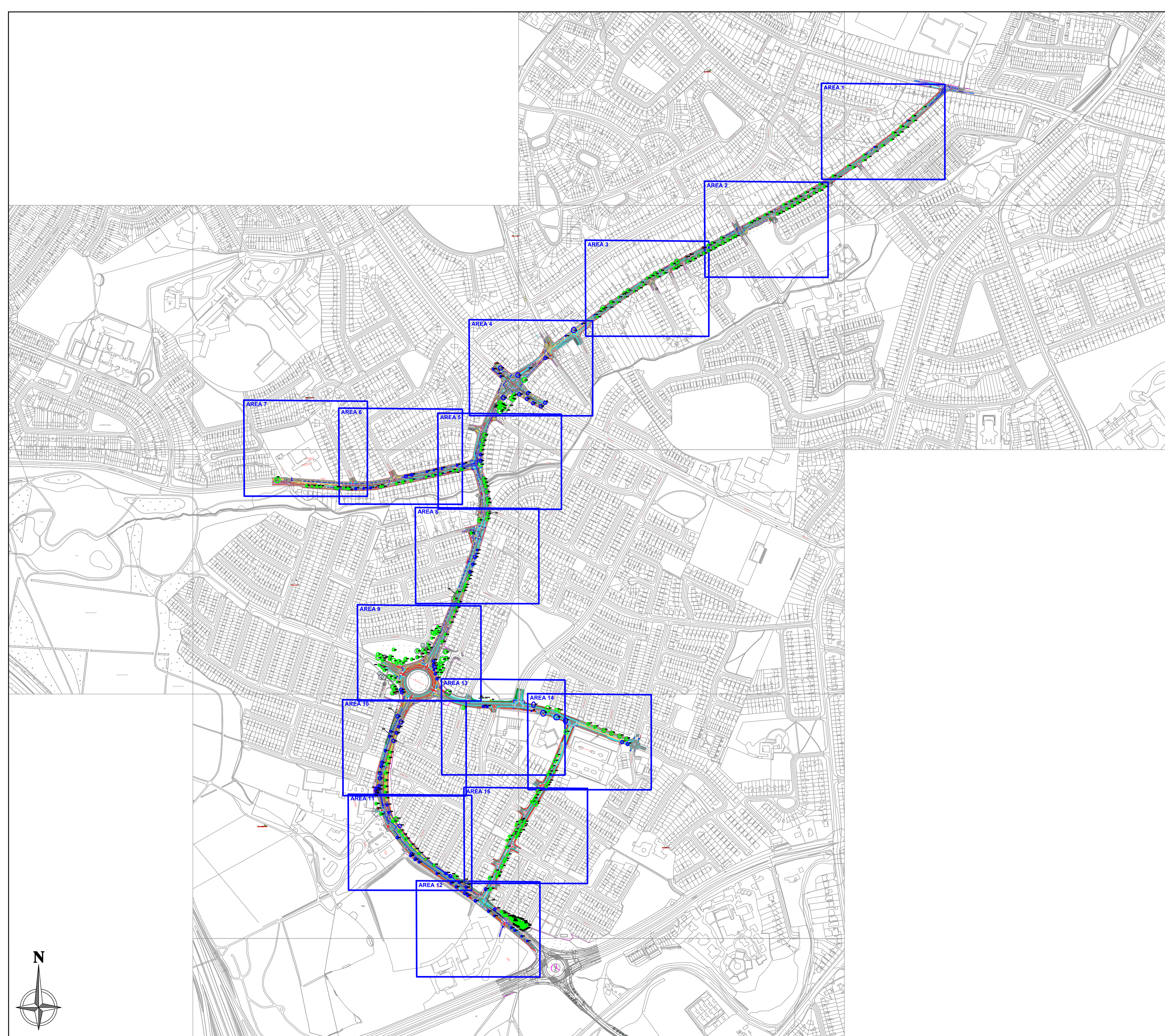

CLIENT



ENGINEERS



LEGEND

**TREE CONDITION CATEGORIES**

- TREES TO BE RETAINED
- TREES TO REMOVE TO FACILITATE CONSTRUCTION
- TREES OF VERY LOW VALUE AND QUALITY TO BE REMOVED IN THE INTERESTS OF SOUND ARBORICULTURAL MANAGEMENT

- CELL WEB
- TREE CONSTRAINTS

Drawing to be interpreted with reference to Tree Survey document

AP refers to approximate position

Tree constraints shown are calculated from guidelines contained within BS5837 (2012) within dimensions contained within Section 8 of the Tree Survey document. This outline should not be interpreted as the exact extent of root spread however it is considered the optimal area to be retained free of developmental impacts. Natural and/or man made barriers such as waterlogged soil or buildings may restrict the spread of tree roots. Crown spreads may also prove to be a constraint particularly where crown reduction may not be possible. The constraints lines shown on this drawing are therefore a guide only. An on-site assessment should be undertaken in the event of any developments being planned within the areas shown for retained trees.

**REVISIONS**

REV	DATE	DESCRIPTION

PROJECT: Limekin Road/Templeogue Wood Road/Rossmore Road/Whitehall Road/ Wellington Road upgrade		JOB NO. TWEL002
DRAWING: ARBORICULTURAL IMPACT (KEYPLAN)	DATE: 31-08-22	SCALE: as shown @ A1
DRAWN BY: NIAL MCBRIDE		NMB INITIALS
STATUS: PLANNING		REVISION: A
DRAWING NO. 129		

**NOTES**  
Do Not Scale - Use Figure Dimensions Only  
Not for Construction Purpose unless Specifically Marked  
© THIS DRAWING IS COPYRIGHT OF CMK HORTICULTURE + ARBORICULTURE LTD.



# AREA 1

CLIENT



ENGINEERS



LEGEND

- TREE CONDITION CATEGORIES**
- TREES TO BE RETAINED
  - TREES TO REMOVE TO FACILITATE CONSTRUCTION
  - TREES OF VERY LOW VALUE AND QUALITY TO BE REMOVED IN THE INTERESTS OF SOUND ARBORICULTURAL MANAGEMENT

- CELL WEB
- TREE CONSTRAINTS

Drawing to be interpreted with reference to Tree Survey document  
 AP refers to approximate position

Tree constraints shown are calculated from guidelines contained within BS5837 (2012) within dimensions contained within Section 8 of the Tree Survey document. This outline should not be interpreted as the exact extent of root spread however it is considered the optimal area to be retained free of developmental impacts. Natural and/or man made barriers such as waterlogged soil or buildings may restrict the spread of tree roots. Crown spreads may also prove to be a constraint particularly where crown reduction may not be possible. The constraints lines shown on this drawing are therefore a guide only. An on-site assessment should be undertaken in the event of any developments being planned within the areas shown for retained trees.

REVISIONS

REV	DATE	DESCRIPTION

PROJECT: Limekiln Road/Templeogue Wood Road/Rossmore Road/Whitehall Road/Wellington Road upgrade

JOB NO. TWEL002

DRAWING: ARBORICULTURAL IMPACT (1 of 15)

DATE: 31-08-22

SCALE: 1:425 @ A1

DRAWN BY: NIAL MCBRIDE

NMB INITIALS

STATUS: PLANNING

REVISION: A

DRAWING NO. 130

NOTES  
 Do Not Scale - Use Figured Dimensions Only  
 Not for Construction Purpose unless Specifically Marked  
 © THIS DRAWING IS COPYRIGHT OF CMK HORTICULTURE + ARBORICULTURE LTD.

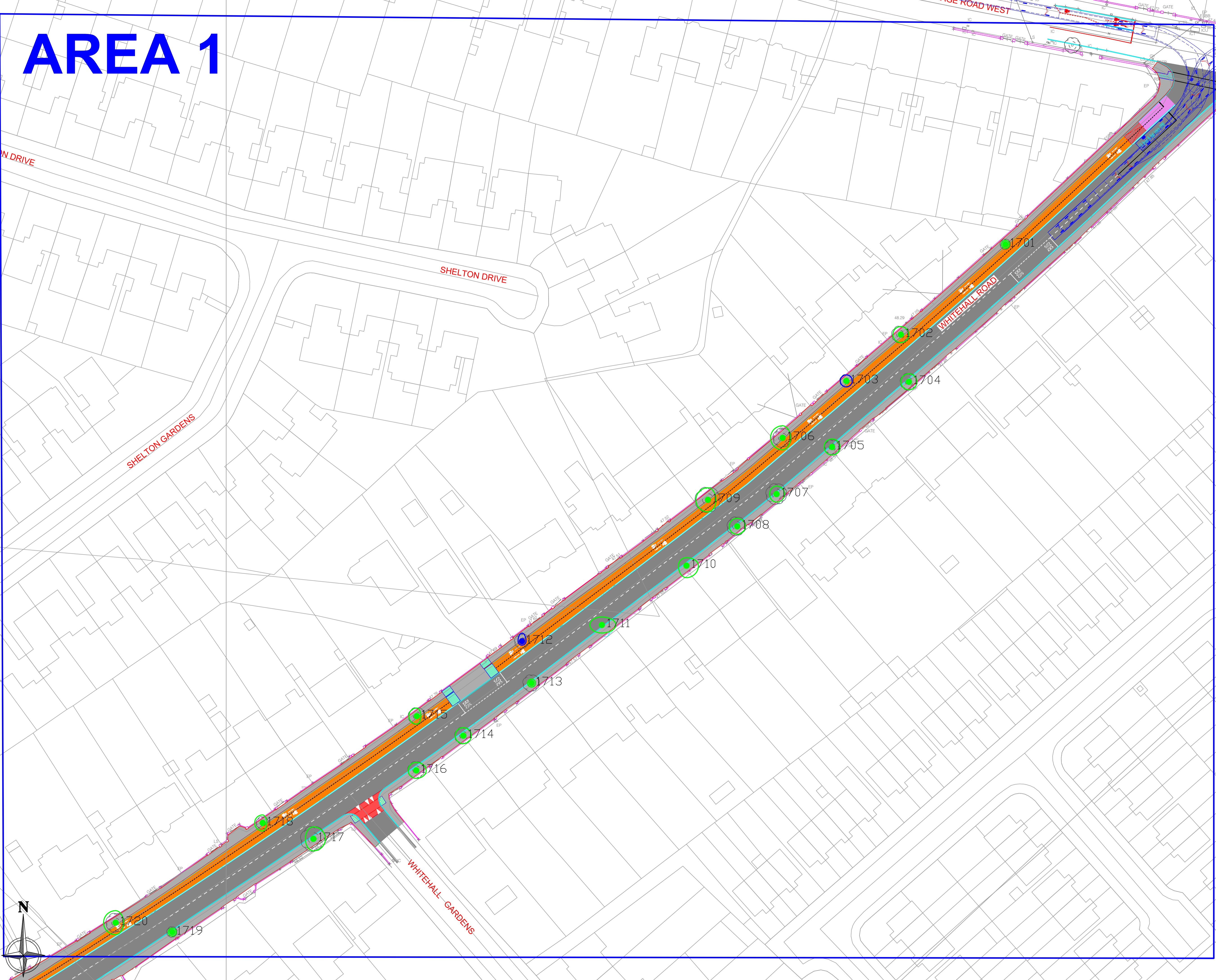

# AREA 2

CLIENT



ENGINEERS



LEGEND

- TREE CONDITION CATEGORIES**
- TREES TO BE RETAINED
  - TREES TO REMOVE TO FACILITATE CONSTRUCTION
  - TREES OF VERY LOW VALUE AND QUALITY TO BE REMOVED IN THE INTERESTS OF SOUND ARBORICULTURAL MANAGEMENT

- CELL WEB
- TREE CONSTRAINTS

Drawing to be interpreted with reference to Tree Survey document  
AP refers to approximate position

Tree constraints shown are calculated from guidelines contained within BS5837 (2012) within dimensions contained within Section 8 of the Tree Survey document. This outline should not be interpreted as the exact extent of root spread however it is considered the optimal area to be retained free of developmental impacts. Natural and/or man made barriers such as waterlogged soil or buildings may restrict the spread of tree roots. Crown spreads may also prove to be a constraint particularly where crown reduction may not be possible. The constraints lines shown on this drawing are therefore a guide only. An on-site assessment should be undertaken in the event of any developments being planned within the areas shown for retained trees.

REVISIONS

REV	DATE	DESCRIPTION

PROJECT: Limekin Road/Templeogue Wood Road/Rossmore Road/Whitehall Road/Wellington Road upgrade

JOB NO. TWEL002

DRAWING: ARBORICULTURAL IMPACT (2of15)

DATE: 31-08-22

SCALE: 1:425 @ A1

DRAWN BY: NIALl MCBRIDE

NMB INITIALS

STATUS: PLANNING

DRAWING NO. 131

REVISION: A

NOTES  
Do Not Scale - Use Figured Dimensions Only  
Not for Construction Purpose unless Specifically Marked  
© THIS DRAWING IS COPYRIGHT OF CMK HORTICULTURE + ARBORICULTURE LTD.

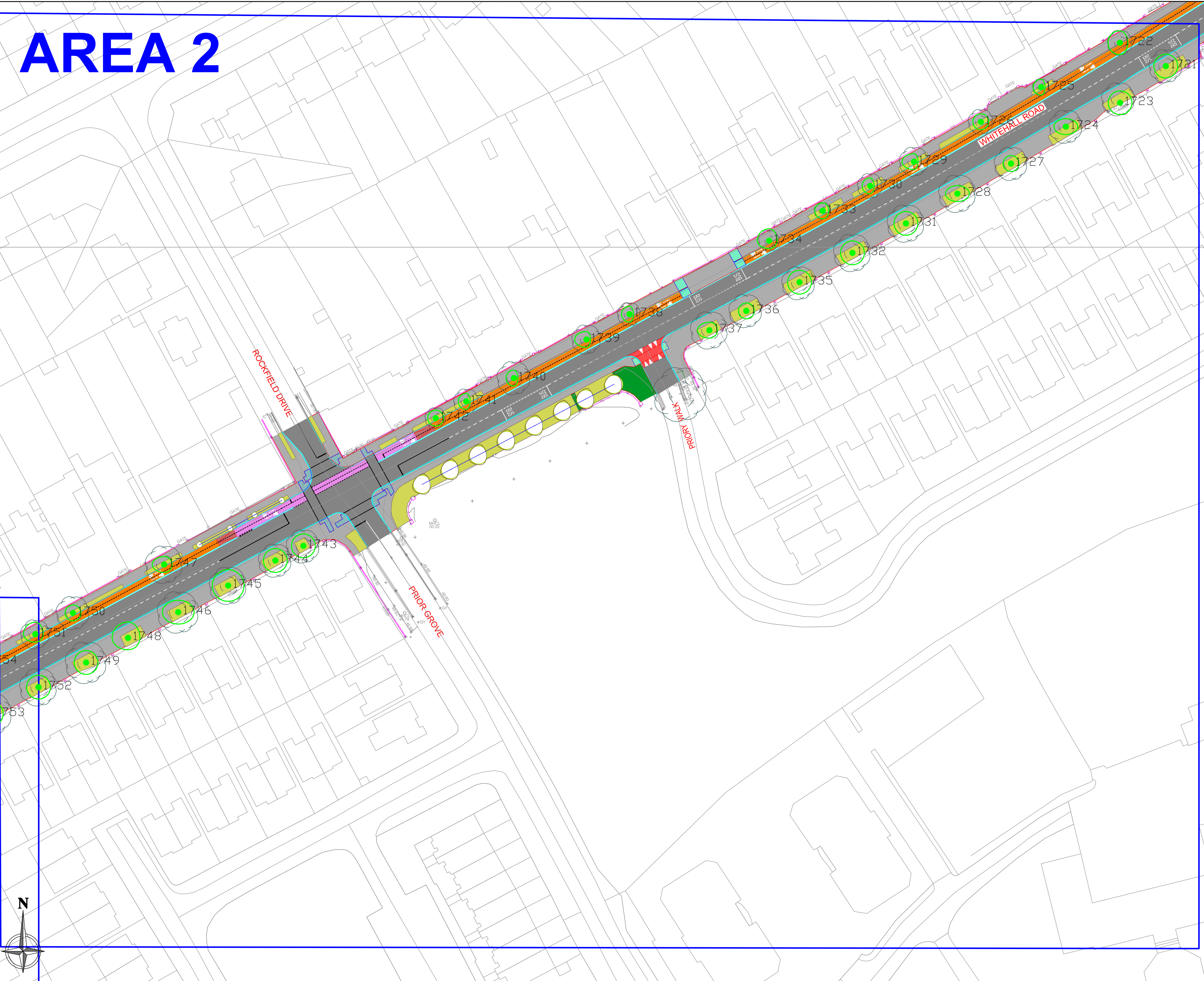
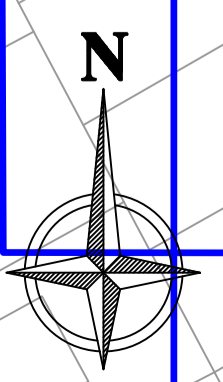

# AREA 3

CLIENT



ENGINEERS



LEGEND

- TREE CONDITION CATEGORIES**
- TREES TO BE RETAINED
  - TREES TO REMOVE TO FACILITATE CONSTRUCTION
  - TREES OF VERY LOW VALUE AND QUALITY TO BE REMOVED IN THE INTERESTS OF SOUND ARBORICULTURAL MANAGEMENT

- CELL WEB
- TREE CONSTRAINTS

Drawing to be interpreted with reference to Tree Survey document  
AP refers to approximate position

Tree constraints shown are calculated from guidelines contained within BS5837 (2012) within dimensions contained within Section 8 of the Tree Survey document. This outline should not be interpreted as the exact extent of root spread however it is considered the optimal area to be retained free of developmental impacts. Natural and/or man made barriers such as waterlogged soil or buildings may restrict the spread of tree roots. Crown spreads may also prove to be a constraint particularly where crown reduction may not be possible. The constraints lines shown on this drawing are therefore a guide only. An on-site assessment should be undertaken in the event of any developments being planned within the areas shown for retained trees.

REVISIONS

REV	DATE	DESCRIPTION

PROJECT: Limekin Road/Templeogue Wood Road/Rossmore Road/Whitehall Road/Wellington Road upgrade

JOB NO. TWEL002

DRAWING: ARBORICULTURAL IMPACT (3of15)

DATE: 31-08-22

SCALE: 1:425 @ A1

DRAWN BY: NIAL MCBRIDE

NMB INITIALS

STATUS: PLANNING

DRAWING NO. 132

REVISION: A

NOTES  
Do Not Scale - Use Figured Dimensions Only  
Not for Construction Purpose unless Specifically Marked  
© THIS DRAWING IS COPYRIGHT OF CMK HORTICULTURE + ARBORICULTURE LTD.

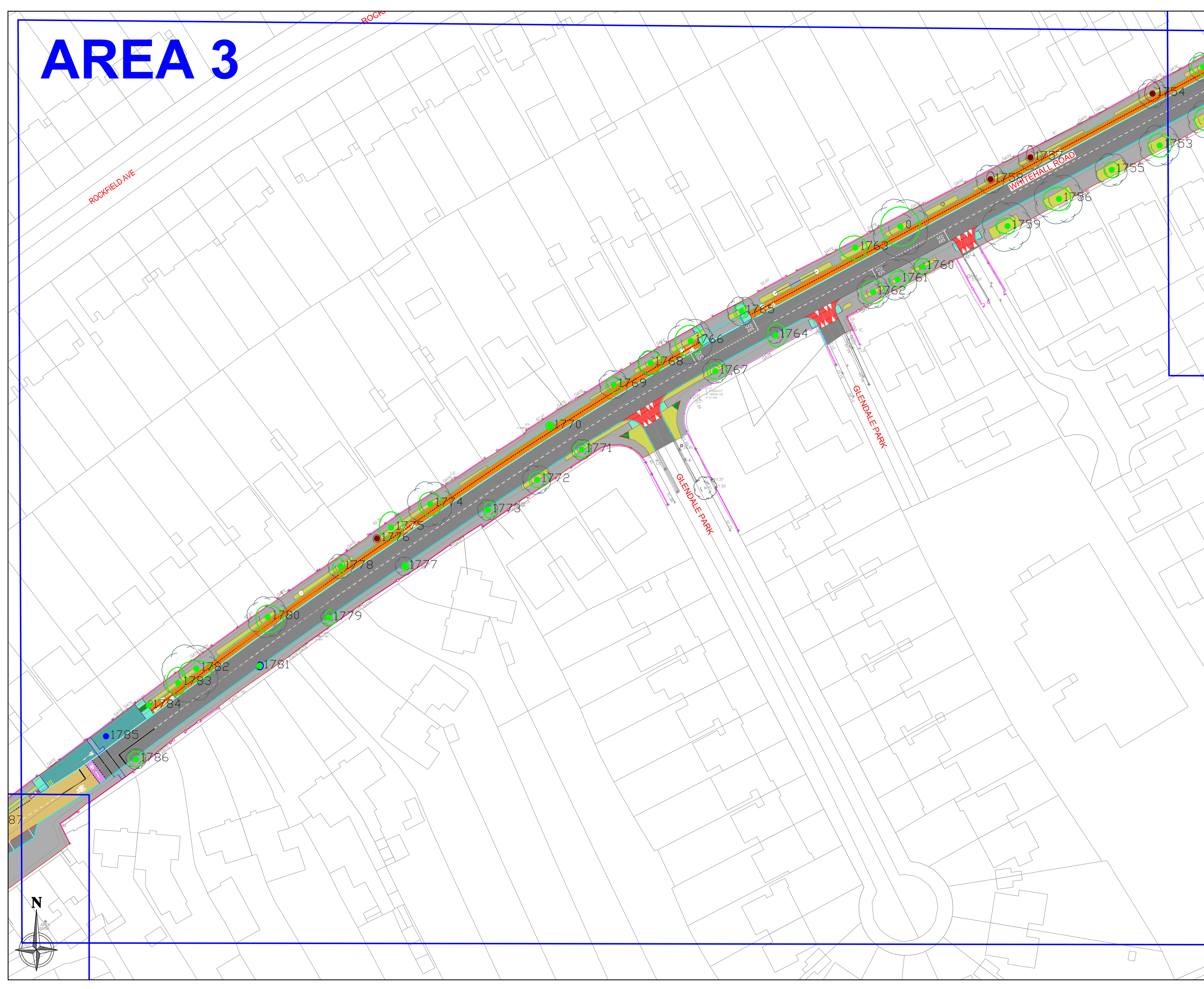

# AREA 4

CLIENT



ENGINEERS



LEGEND

**TREE CONDITION CATEGORIES**

- TREES TO BE RETAINED
- TREES TO REMOVE TO FACILITATE CONSTRUCTION
- TREES OF VERY LOW VALUE AND QUALITY TO BE REMOVED IN THE INTERESTS OF SOUND ARBORICULTURAL MANAGEMENT

- CELL WEB
- TREE CONSTRAINTS

Drawing to be interpreted with reference to Tree Survey document  
 AP refers to approximate position  
 Tree constraints shown are calculated from guidelines contained within BS5837 (2012) within dimensions contained within Section 8 of the Tree Survey document. This outline should not be interpreted as the exact extent of root spread however it is considered the optimal area to be retained free of developmental impacts.  
 Natural and/or man made barriers such as waterlogged soil or buildings may restrict the spread of tree roots. Crown spreads may also prove to be a constraint particularly where crown reduction may not be possible.  
 The constraints lines shown on this drawing are therefore a guide only. An on-site assessment should be undertaken in the event of any developments being planned within the areas shown for retained trees.

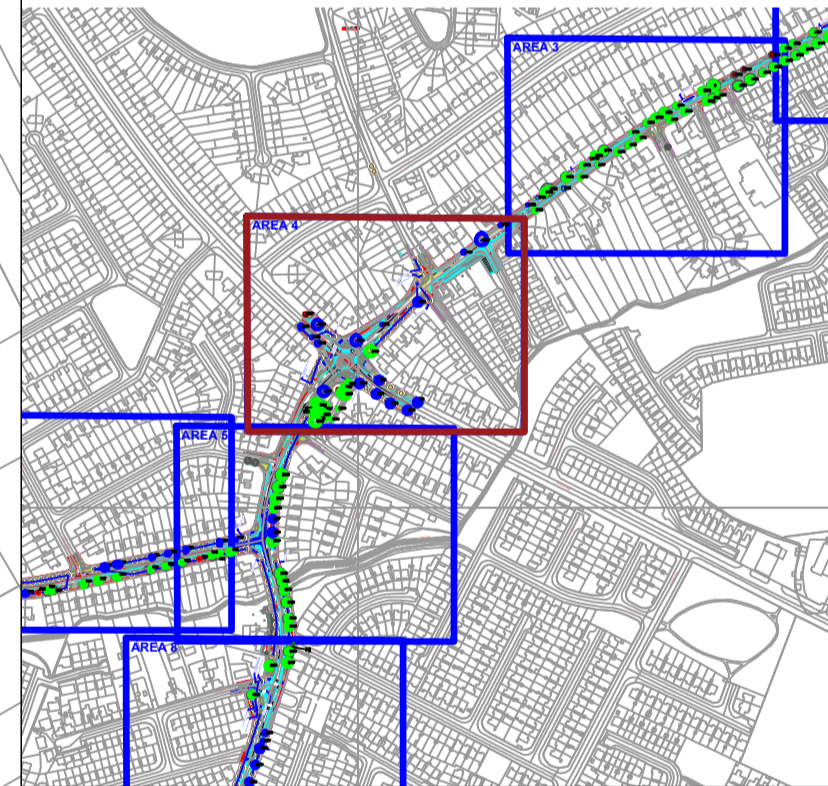

REVISIONS

REV	DATE	DESCRIPTION

PROJECT: Limekin Road/Templeogue Wood Road/Rossmore Road/Whitehall Road/ Wellington Road upgrade		JOB NO. TWEL002
DRAWING: ARBORICULTURAL IMPACT (4of15)	DATE: 31-08-22	SCALE: 1:425 @ A1
DRAWN BY: NIAL MCBRIDE		NMB INITIALS
STATUS: PLANNING		REVISION: A
DRAWING NO. 133		

NOTES  
 Do Not Scale: Use Figured Dimensions Only  
 Not for Construction Purpose unless Specifically Marked  
 © THIS DRAWING IS COPYRIGHT OF CMK HORTICULTURE + ARBORICULTURE LTD.

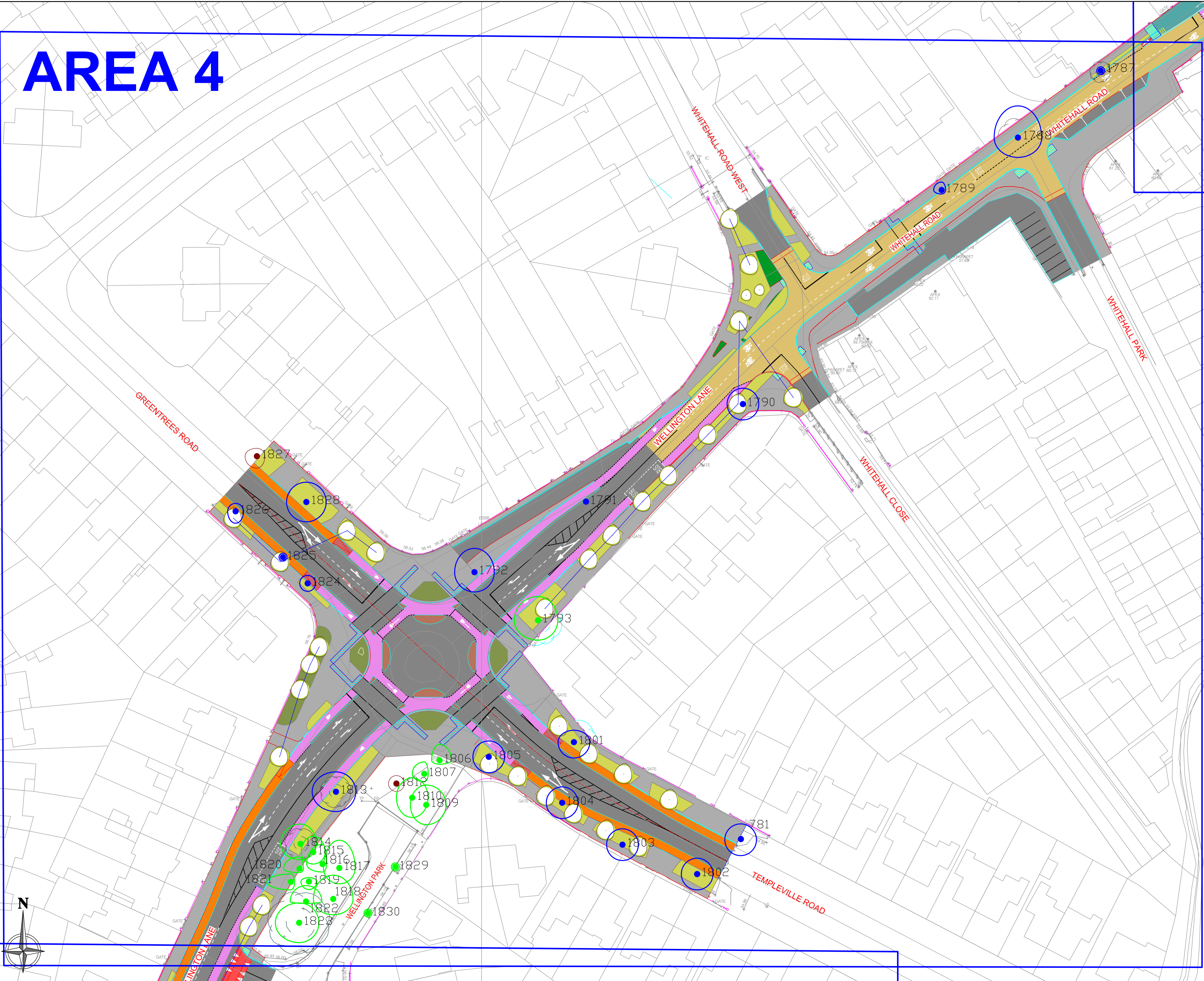
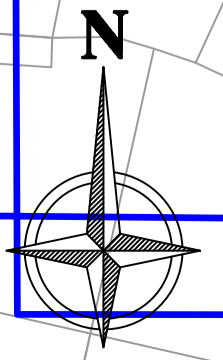

# AREA 5

CLIENT



ENGINEERS



LEGEND

- TREE CONDITION CATEGORIES**
- TREES TO BE RETAINED
  - TREES TO REMOVE TO FACILITATE CONSTRUCTION
  - TREES OF VERY LOW VALUE AND QUALITY TO BE REMOVED IN THE INTERESTS OF SOUND ARBORICULTURAL MANAGEMENT

- CELL WEB
- TREE CONSTRAINTS

Drawing to be interpreted with reference to Tree Survey document  
AP refers to approximate position

Tree constraints shown are calculated from guidelines contained within BS5837 (2012) within dimensions contained within Section 8 of the Tree Survey document. This outline should not be interpreted as the exact extent of root spread however it is considered the optimal area to be retained free of developmental impacts. Natural and/or man made barriers such as waterlogged soil or buildings may restrict the spread of tree roots. Crown spreads may also prove to be a constraint particularly where crown reduction may not be possible. The constraints lines shown on this drawing are therefore a guide only. An on-site assessment should be undertaken in the event of any developments being planned within the areas shown for retained trees.

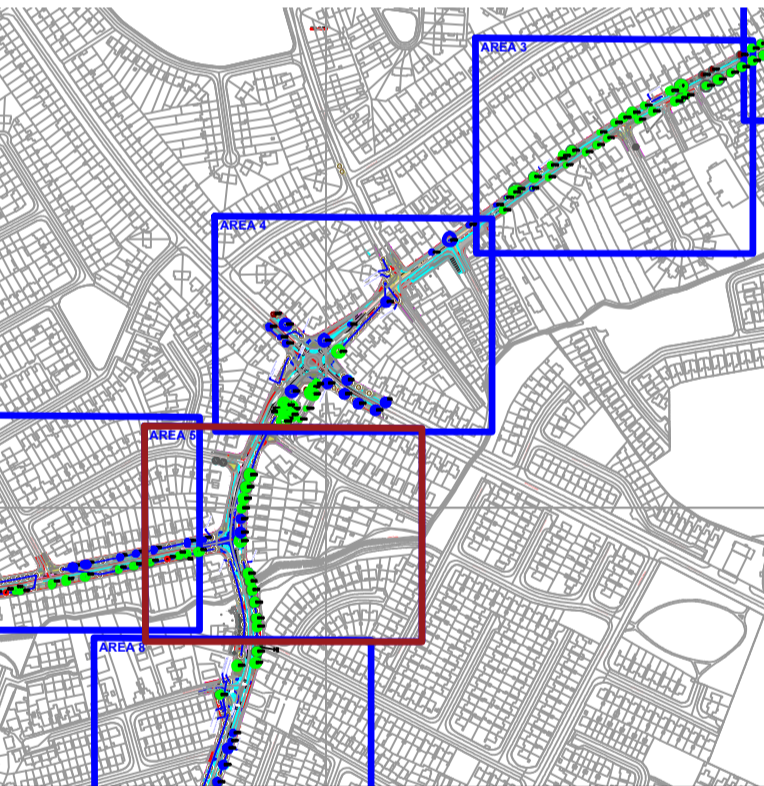

REVISIONS

REV	DATE	DESCRIPTION

PROJECT: Limekiln Road/Templeogue Wood Road/Rossmore Road/Whitehall Road/ Wellington Road upgrade

JOB NO. TWEL002

DRAWING: ARBORICULTURAL IMPACT (Sof15)

DATE: 31-08-22

SCALE: 1:425 @ A1

DRAWN BY: NIALL MCBRIDE

NMB INITIALS

STATUS: PLANNING

DRAWING NO. 134

REVISION: A

NOTES  
Do Not Scale - Use Figured Dimensions Only  
Not for Construction Purpose unless Specifically Marked  
© THIS DRAWING IS COPYRIGHT OF CMK HORTICULTURE + ARBORICULTURE LTD.

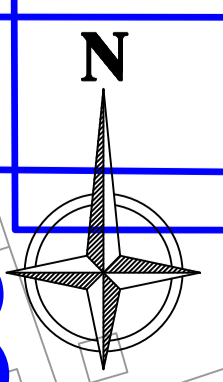
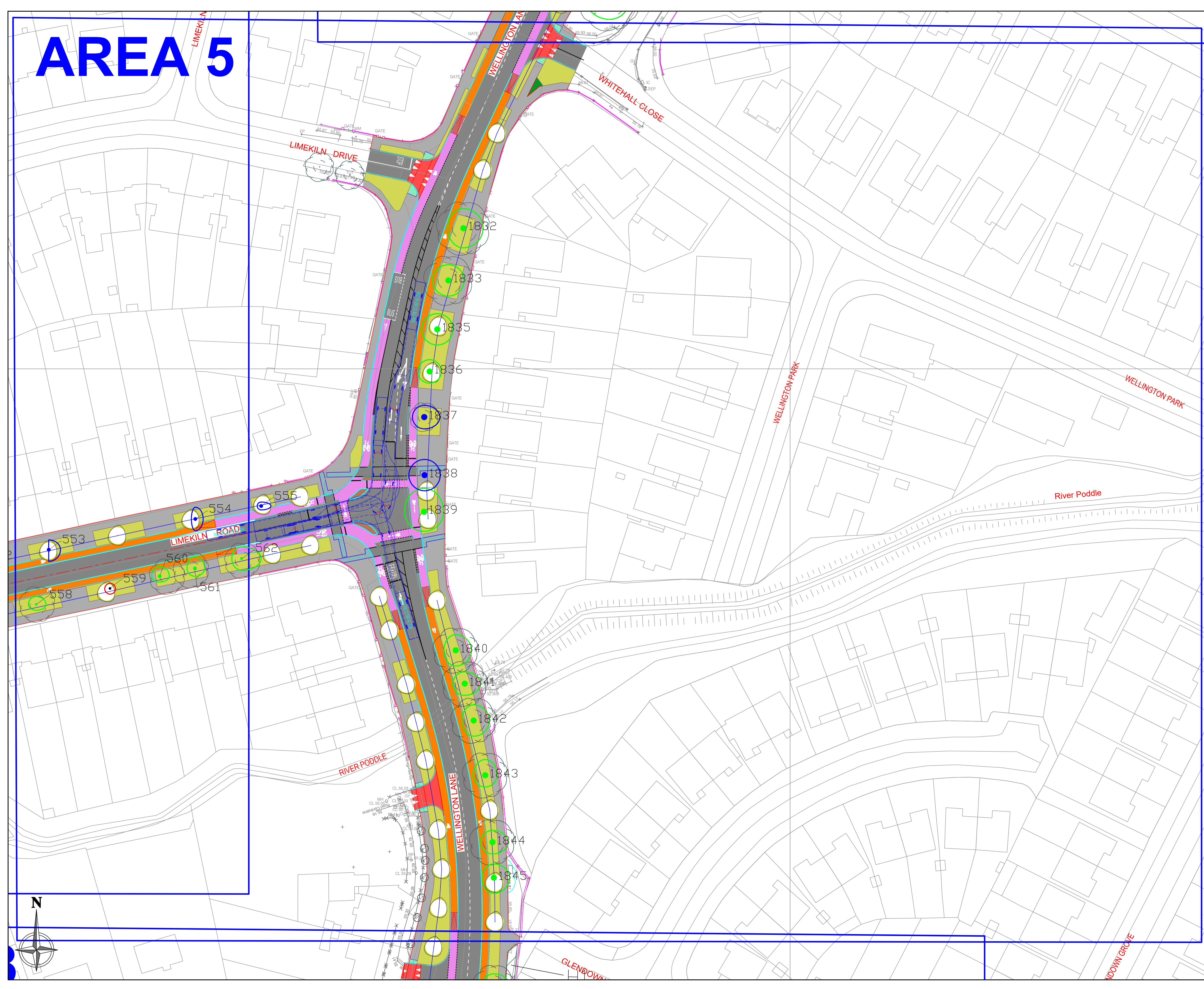



# AREA 6

# AREA 5

CLIENT



ENGINEERS



LEGEND

- TREE CONDITION CATEGORIES**
- TREES TO BE RETAINED
  - TREES TO REMOVE TO FACILITATE CONSTRUCTION
  - TREES OF VERY LOW VALUE AND QUALITY TO BE REMOVED IN THE INTERESTS OF SOUND ARBORICULTURAL MANAGEMENT

- CELL WEB
- TREE CONSTRAINTS

Drawing to be interpreted with reference to Tree Survey document  
AP refers to approximate position

Tree constraints shown are calculated from guidelines contained within BS5837 (2012) within dimensions contained within Section 8 of the Tree Survey document. This outline should not be interpreted as the exact extent of root spread however it is considered the optimal area to be retained free of developmental impacts.  
Natural and/or man made barriers such as waterlogged soil or buildings may restrict the spread of tree roots. Crown spreads may also prove to be a constraint particularly where crown reduction may not be possible.  
The constraints lines shown on this drawing are therefore a guide only. An on-site assessment should be undertaken in the event of any developments being planned within the areas shown for retained trees.



REVISIONS

REV	DATE	DESCRIPTION

PROJECT: Limekiln Road/Templeogue Wood Road/Rossmore Road/Whitehall Road/Wellington Road upgrade

JOB NO. TWEL002

DRAWING: ARBORICULTURAL IMPACT (6of15)

DATE: 31-08-22

SCALE: 1:425 @ A1

DRAWN BY: NIAL MCBRIDE

NMB INITIALS

STATUS: PLANNING

REVISION: A

DRAWING NO. 135

NOTES  
Do Not Scale - Use Figure Dimensions Only  
Not for Construction Purpose unless Specifically Marked  
© THIS DRAWING IS COPYRIGHT OF CMK HORTICULTURE + ARBORICULTURE LTD.

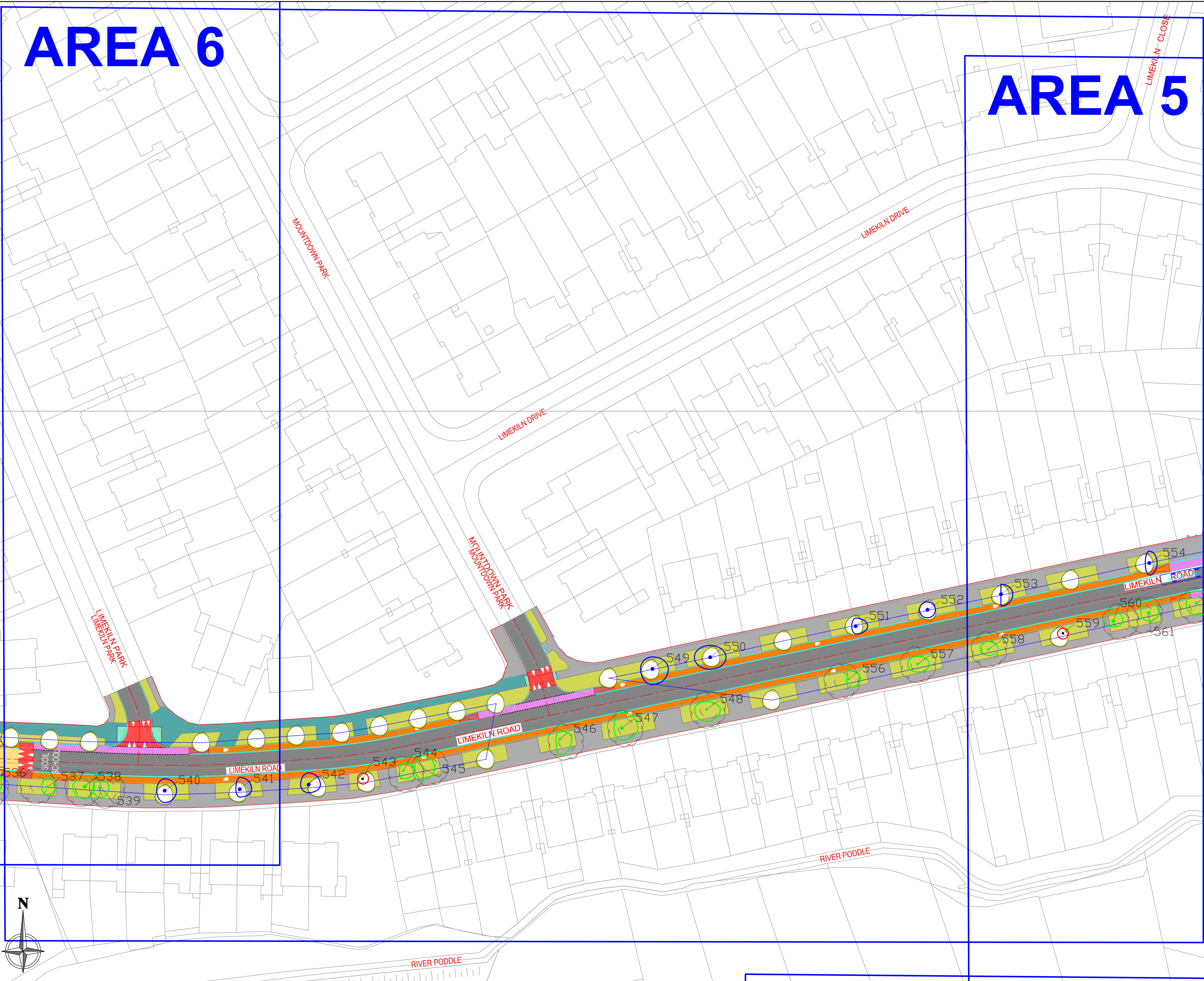
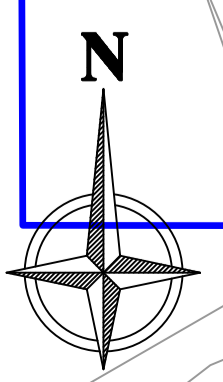

# AREA 7

# AREA 6

CLIENT



ENGINEERS



LEGEND

**TREE CONDITION CATEGORIES**

- TREES TO BE RETAINED
- TREES TO REMOVE TO FACILITATE CONSTRUCTION
- TREES OF VERY LOW VALUE AND QUALITY TO BE REMOVED IN THE INTERESTS OF SOUND ARBORICULTURAL MANAGEMENT

- CELL WEB
- TREE CONSTRAINTS

Drawing to be interpreted with reference to Tree Survey document  
AP refers to approximate position

Tree constraints shown are calculated from guidelines contained within BS5837 (2012) within dimensions contained within Section 8 of the Tree Survey document. This outline should not be interpreted as the exact extent of root spread however it is considered the optimal area to be retained free of developmental impacts. Natural and/or man made barriers such as waterlogged soil or buildings may restrict the spread of tree roots. Crown spreads may also prove to be a constraint particularly where crown reduction may not be possible. The constraints lines shown on this drawing are therefore a guide only. An on-site assessment should be undertaken in the event of any developments being planned within the areas shown for retained trees.

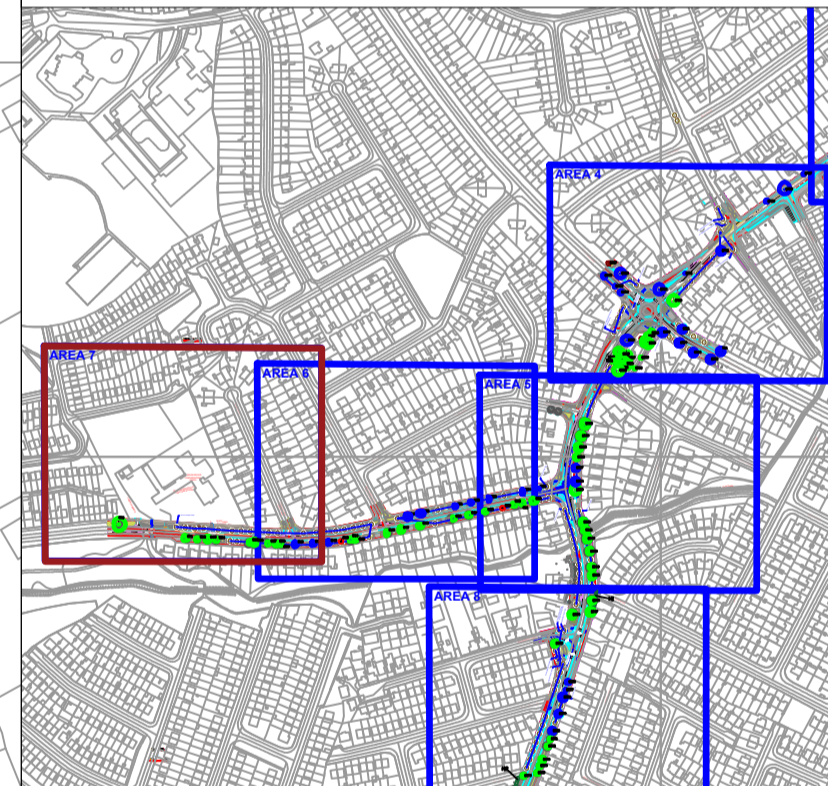

**REVISIONS**

REV	DATE	DESCRIPTION

PROJECT: Limekiln Road/Templeogue Wood Road/Rossmore Road/Whitehall Road/ Wellington Road upgrade	JOB NO. TWEL002
DRAWING: ARBORICULTURAL IMPACT (7 of 15)	DATE: 31-08-22
DRAWN BY: NIALL MCBRIDE	SCALE: 1:425 @ A1
STATUS: PLANNING	NMB INITIALS
DRAWING NO. 136	REVISION: A

**NOTES**  
Do Not Scale - Use Figured Dimensions Only  
Not for Construction Purpose unless Specifically Marked  
© THIS DRAWING IS COPYRIGHT OF CMK HORTICULTURE + ARBORICULTURE LTD.

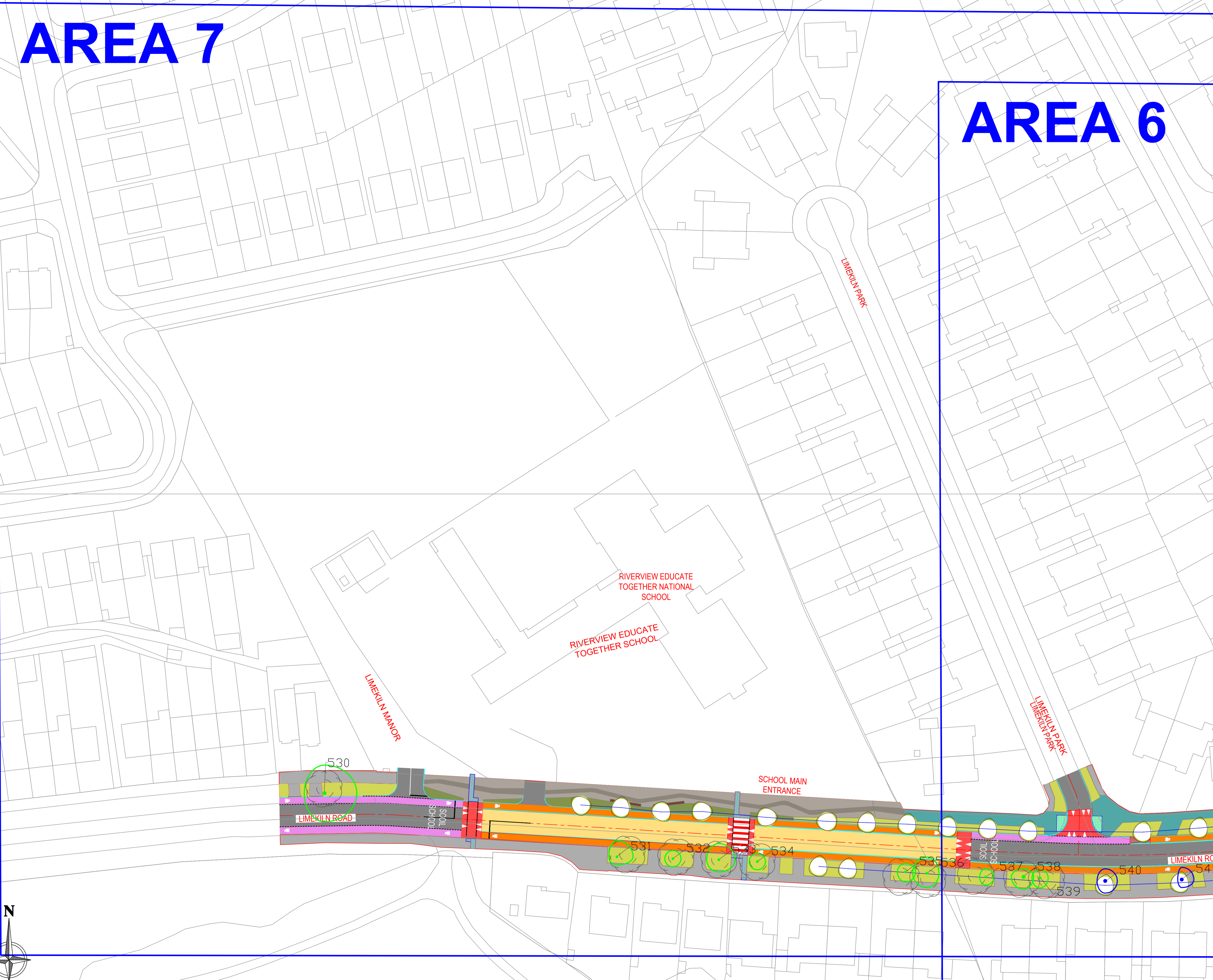
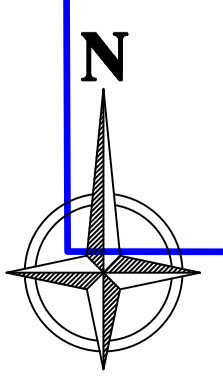

# AREA 8

CLIENT



ENGINEERS



LEGEND

- TREE CONDITION CATEGORIES**
- TREES TO BE RETAINED
  - TREES TO REMOVE TO FACILITATE CONSTRUCTION
  - TREES OF VERY LOW VALUE AND QUALITY TO BE REMOVED IN THE INTERESTS OF SOUND ARBORICULTURAL MANAGEMENT

- CELL WEB
- TREE CONSTRAINTS

Drawing to be interpreted with reference to Tree Survey document  
AP refers to approximate position

Tree constraints shown are calculated from guidelines contained within BS5837 (2012) within dimensions contained within Section 8 of the Tree Survey document. This outline should not be interpreted as the exact extent of root spread however it is considered the optimal area to be retained free of developmental impacts. Natural and/or man made barriers such as waterlogged soil or buildings may restrict the spread of tree roots. Crown spreads may also prove to be a constraint particularly where crown reduction may not be possible. The constraints lines shown on this drawing are therefore a guide only. An on-site assessment should be undertaken in the event of any developments being planned within the areas shown for retained trees.



REVISIONS

REV	DATE	DESCRIPTION

PROJECT: Limekiln Road/Templeogue Wood Road/Rossmore Road/Whitehall Road/Wellington Road upgrade  
JOB NO: TWEL002

DRAWING: ARBORICULTURAL IMPACT (8of15)  
DATE: 31-08-22  
SCALE: 1:425 @ A1

DRAWN BY: NIALL MCBRIDE  
NMB INITIALS

STATUS: PLANNING  
DRAWING NO. 137  
REVISION: A

NOTES  
Do Not Scale: Use Figured Dimensions Only  
Not for Construction Purpose unless Specifically Marked  
© THIS DRAWING IS COPYRIGHT OF CMK HORTICULTURE + ARBORICULTURE LTD.

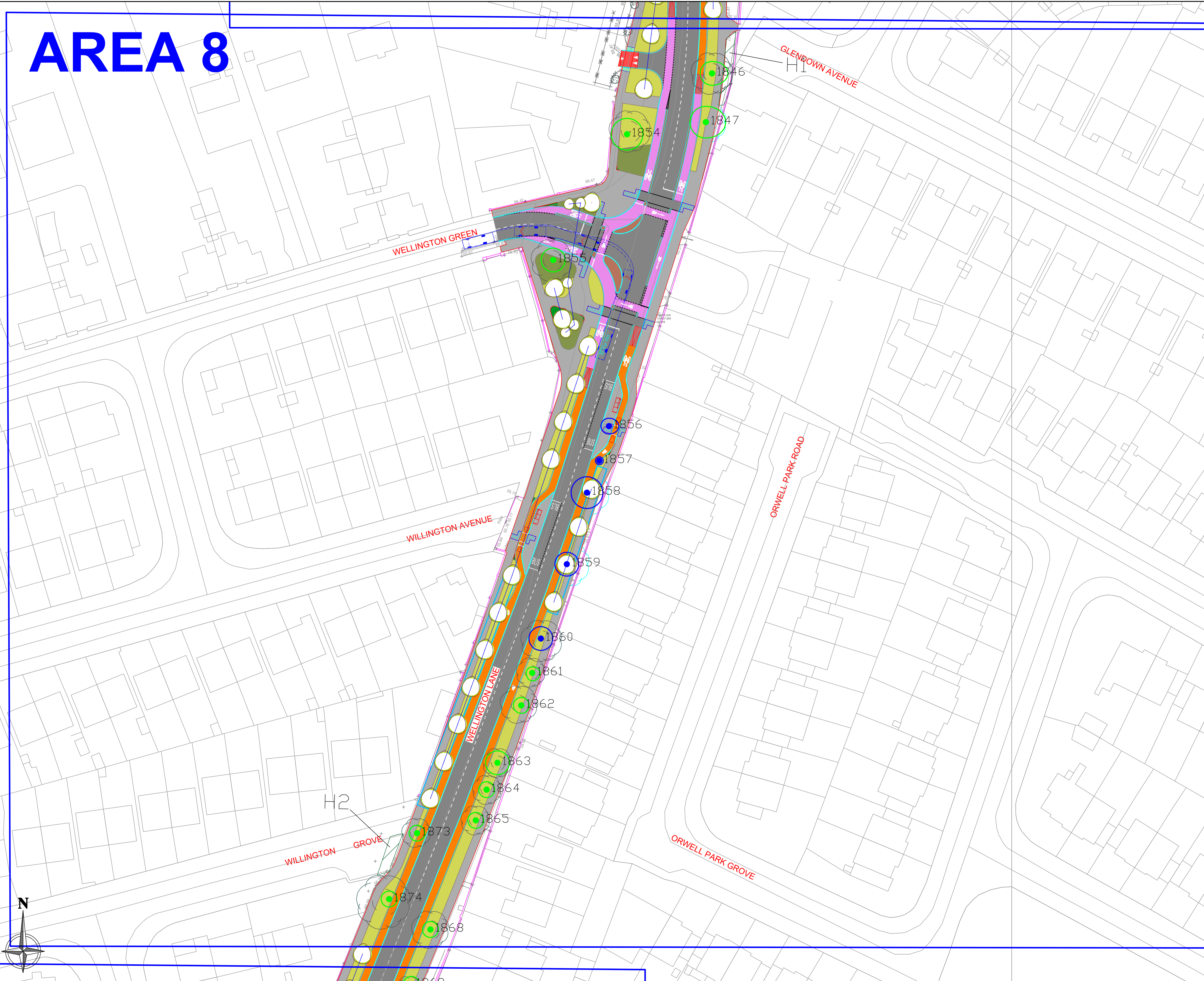
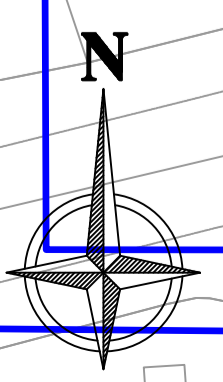

# AREA 9

CLIENT



ENGINEERS



LEGEND

- TREE CONDITION CATEGORIES**
- TREES TO BE RETAINED
  - TREES TO REMOVE TO FACILITATE CONSTRUCTION
  - TREES OF VERY LOW VALUE AND QUALITY TO BE REMOVED IN THE INTERESTS OF SOUND ARBORICULTURAL MANAGEMENT

- CELL WEB
- TREE CONSTRAINTS

Drawing to be interpreted with reference to Tree Survey document  
AP refers to approximate position

Tree constraints shown are calculated from guidelines contained within BS5837 (2012) within dimensions contained within Section 8 of the Tree Survey document. This outline should not be interpreted as the exact extent of root spread however it is considered the optimal area to be retained free of developmental impacts. Natural and/or man made barriers such as waterlogged soil or buildings may restrict the spread of tree roots. Crown spreads may also prove to be a constraint particularly where crown reduction may not be possible. The constraints lines shown on this drawing are therefore a guide only. An on-site assessment should be undertaken in the event of any developments being planned within the areas shown for retained trees.

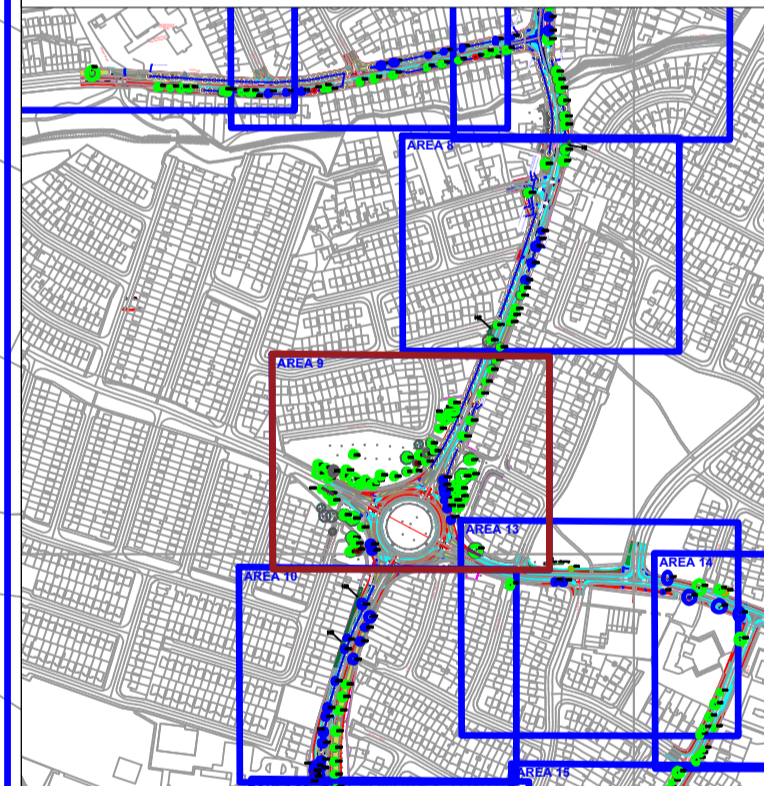

REVISIONS

REV	DATE	DESCRIPTION

PROJECT: Limekiln Road/Templeogue Wood Road/Rossmore Road/Whitehall Road/Wellington Road upgrade

JOB NO. TWEL002

DRAWING: ARBORICULTURAL IMPACT (9of15)

DATE: 31-08-22

SCALE: 1:425 @ A1

DRAWN BY: NIALL MCBRIDE

NMB INITIALS

STATUS: PLANNING

REVISION: A

DRAWING NO. 138

NOTES  
Do Not Scale - Use Figured Dimensions Only  
Not for Construction Purpose unless Specifically Marked  
© THIS DRAWING IS COPYRIGHT OF CMK HORTICULTURE + ARBORICULTURE LTD.

# AREA 13

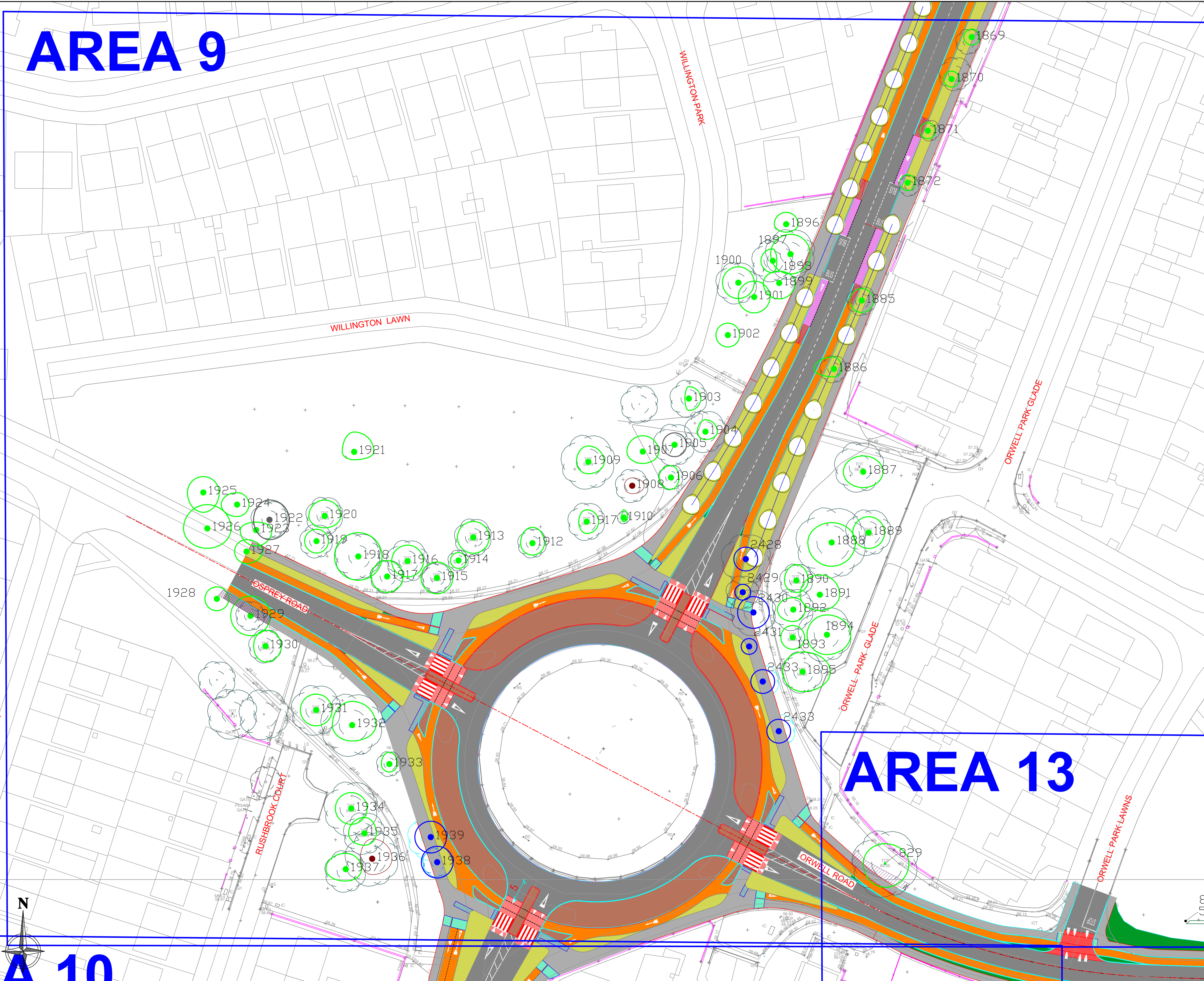
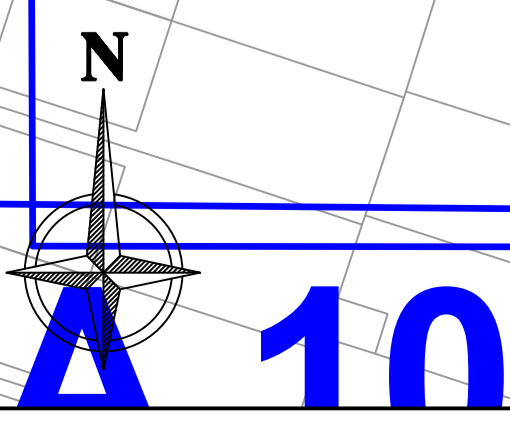

# AREA 10

CLIENT



ENGINEERS



LEGEND

- TREE CONDITION CATEGORIES**
- TREES TO BE RETAINED
  - TREES TO REMOVE TO FACILITATE CONSTRUCTION
  - TREES OF VERY LOW VALUE AND QUALITY TO BE REMOVED IN THE INTERESTS OF SOUND ARBORICULTURAL MANAGEMENT

- CELL WEB
- TREE CONSTRAINTS

Drawing to be interpreted with reference to Tree Survey document  
AP refers to approximate position

Tree constraints shown are calculated from guidelines contained within BS5837 (2012) within dimensions contained within Section 8 of the Tree Survey document. This outline should not be interpreted as the exact extent of root spread however it is considered the optimal area to be retained free of developmental impacts. Natural and/or man made barriers such as waterlogged soil or buildings may restrict the spread of tree roots. Crown spreads may also prove to be a constraint particularly where crown reduction may not be possible. The constraints lines shown on this drawing are therefore a guide only. An on-site assessment should be undertaken in the event of any developments being planned within the areas shown for retained trees.

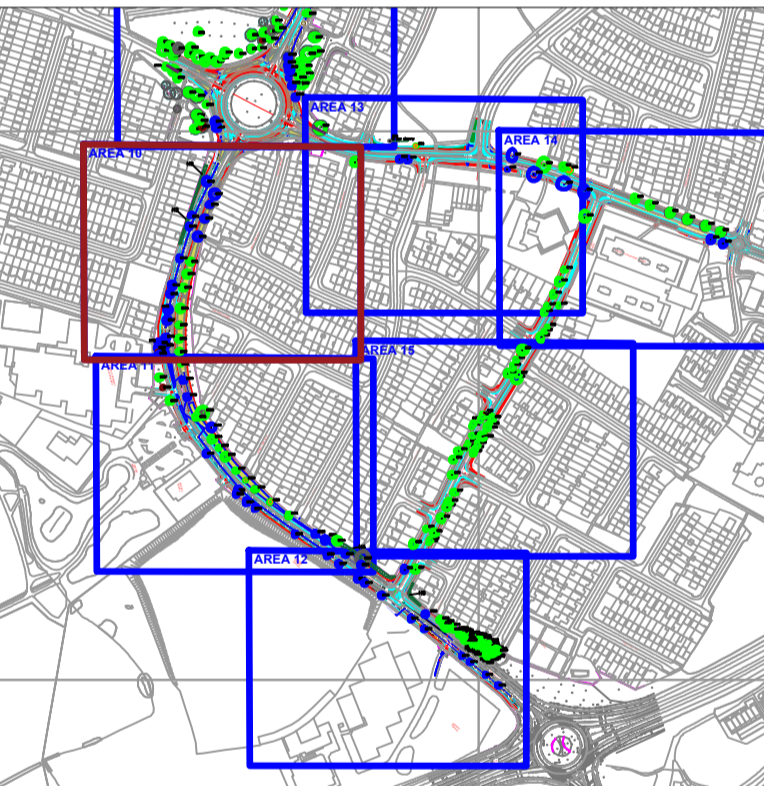

REVISIONS

REV	DATE	DESCRIPTION

PROJECT: Limekiln Road/Tempogue Wood Road/Rossmore Road/Whitehall Road/Wellington Road upgrade

JOB NO. TWEL002

DRAWING: ARBORICULTURAL IMPACT (100f15)

DATE: 31-08-22

SCALE: 1:425 @ A1

DRAWN BY: NIALL MCBRIDE

NMB INITIALS

STATUS: PLANNING

DRAWING NO. 139

REVISION: A

NOTES  
Do Not Scale - Use Figured Dimensions Only  
Not for Construction Purpose unless Specifically Marked  
© THIS DRAWING IS COPYRIGHT OF CMK HORTICULTURE + ARBORICULTURE LTD.

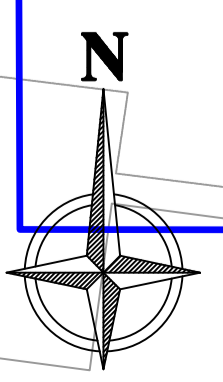

# AREA 11

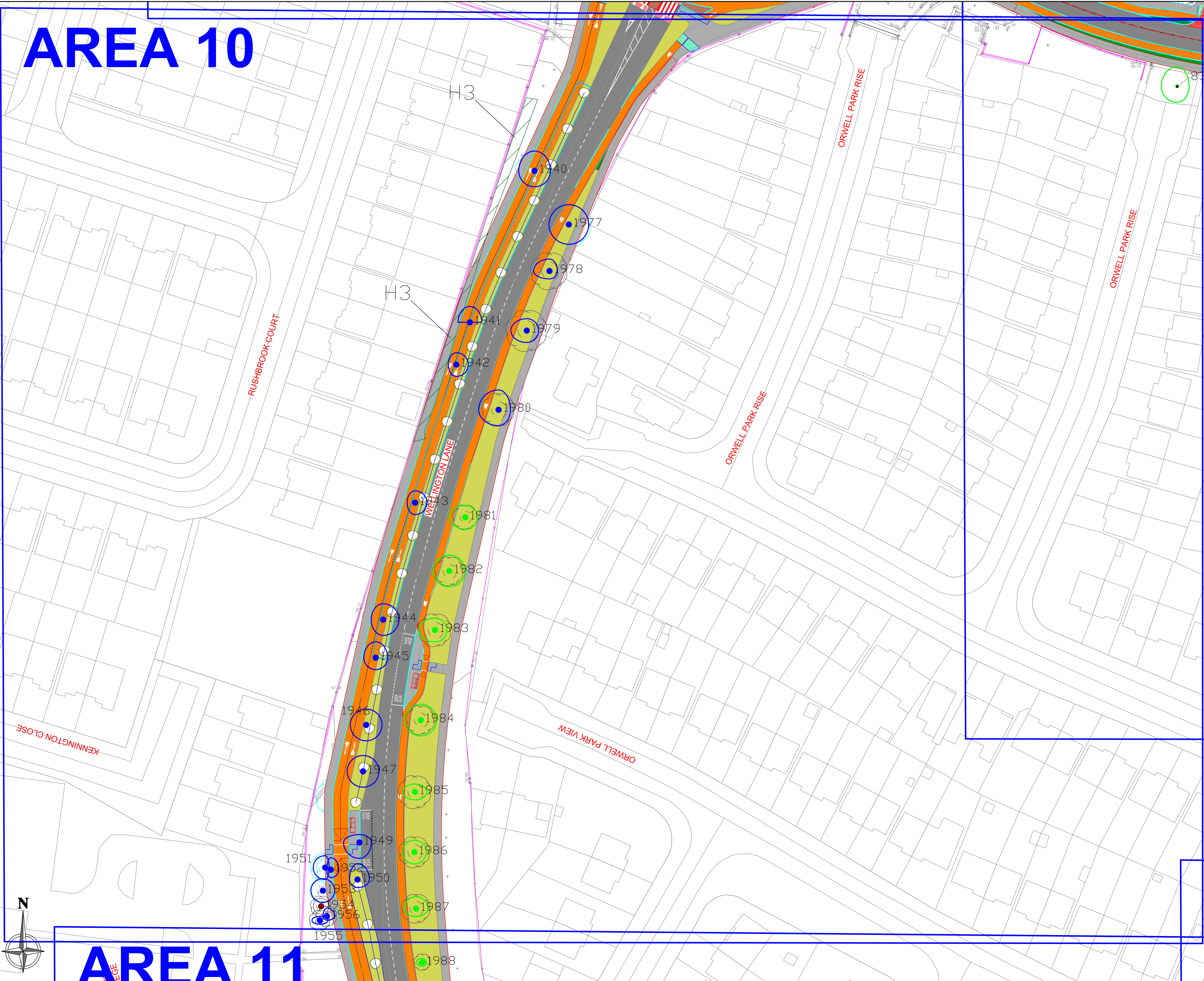

# AREA 11

# AREA 12

CLIENT



ENGINEERS



LEGEND

- TREE CONDITION CATEGORIES**
- TREES TO BE RETAINED
  - TREES TO REMOVE TO FACILITATE CONSTRUCTION
  - TREES OF VERY LOW VALUE AND QUALITY TO BE REMOVED IN THE INTERESTS OF SOUND ARBORICULTURAL MANAGEMENT

- CELL WEB
- TREE CONSTRAINTS

Drawing to be interpreted with reference to Tree Survey document  
AP refers to approximate position

Tree constraints shown are calculated from guidelines contained within BS5837 (2012) within dimensions contained within Section 8 of the Tree Survey document. This outline should not be interpreted as the exact extent of root spread however it is considered the optimal area to be retained free of developmental impacts. Natural and/or man made barriers such as waterlogged soil or buildings may restrict the spread of tree roots. Crown spreads may also prove to be a constraint particularly where crown reduction may not be possible. The constraints lines shown on this drawing are therefore a guide only. An on-site assessment should be undertaken in the event of any developments being planned within the areas shown for retained trees.

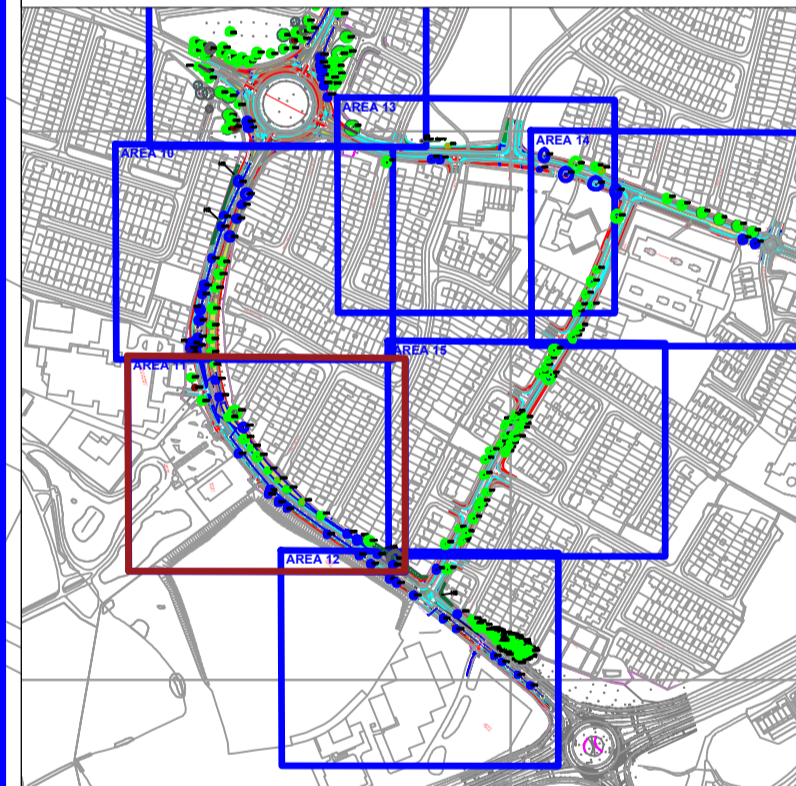

REVISIONS

REV	DATE	DESCRIPTION

PROJECT: Limekiln Road/Templeogue Wood Road/Rossmore Road/Whitehall Road/ Wellington Road upgrade	JOB NO. TWEL002
---	--------------------

DRAWING: ARBORICULTURAL IMPACT (11of15)	DATE: 31-08-22	SCALE: 1:425 @ A1
--	-------------------	----------------------

DRAWN BY: NIALL MCBRIDE	NMB INITIALS
-------------------------	-----------------

STATUS: PLANNING	REVISION: A
------------------	----------------

DRAWING NO. 140
-----------------

NOTES  
Do Not Scale - Use Figured Dimensions Only  
Not for Construction Purpose unless Specifically Marked  
© THIS DRAWING IS COPYRIGHT OF CMK HORTICULTURE + ARBORICULTURE LTD.

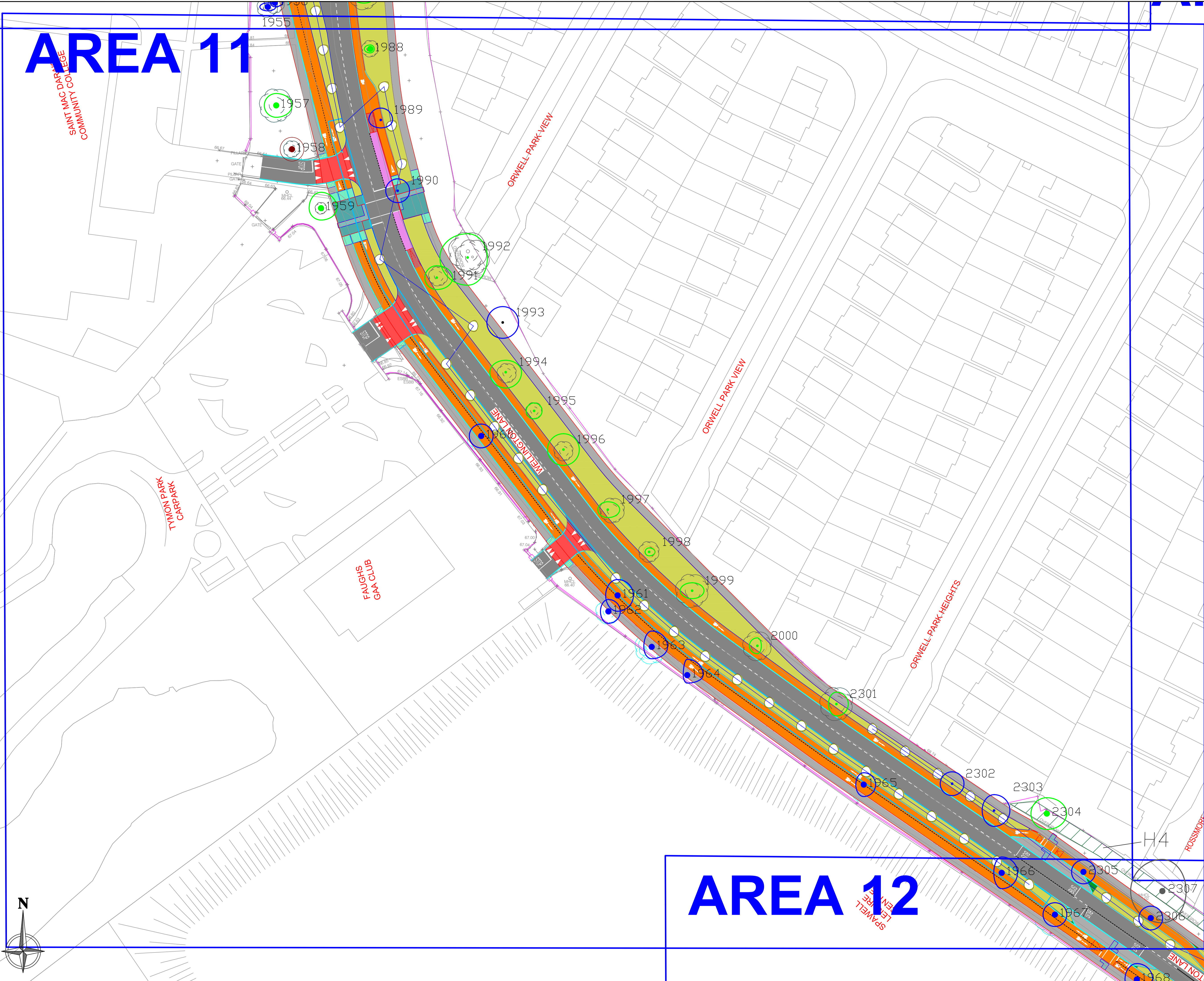
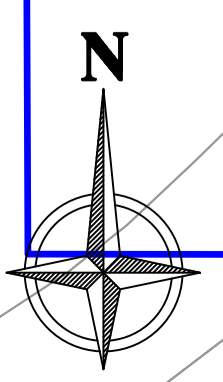

# AREA 12

SPAWELL CARPARK

CLIENT



ENGINEERS

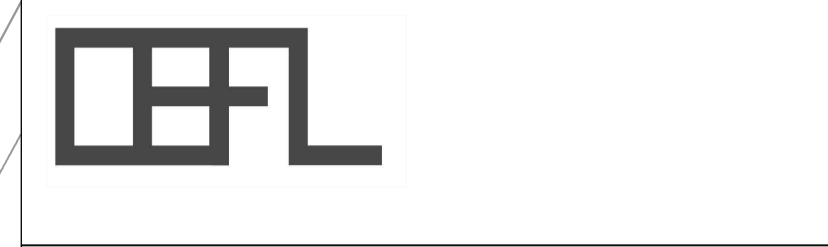

LEGEND

- TREE CONDITION CATEGORIES**
- TREES TO BE RETAINED
  - TREES TO REMOVE TO FACILITATE CONSTRUCTION
  - TREES OF VERY LOW VALUE AND QUALITY TO BE REMOVED IN THE INTERESTS OF SOUND ARBORICULTURAL MANAGEMENT

- CELL VEB
- TREE CONSTRAINTS

Drawing to be interpreted with reference to Tree Survey document  
AP refers to approximate position

Tree constraints shown are calculated from guidelines contained within BS5837 (2012) within dimensions contained within Section 8 of the Tree Survey document. This outline should not be interpreted as the exact extent of root spread however it is considered the optimal area to be retained free of developmental impacts. Natural and/or man made barriers such as waterlogged soil or buildings may restrict the spread of tree roots. Crown spreads may also prove to be a constraint particularly where crown reduction may not be possible. The constraints lines shown on this drawing are therefore a guide only. An on-site assessment should be undertaken in the event of any developments being planned within the areas shown for retained trees.

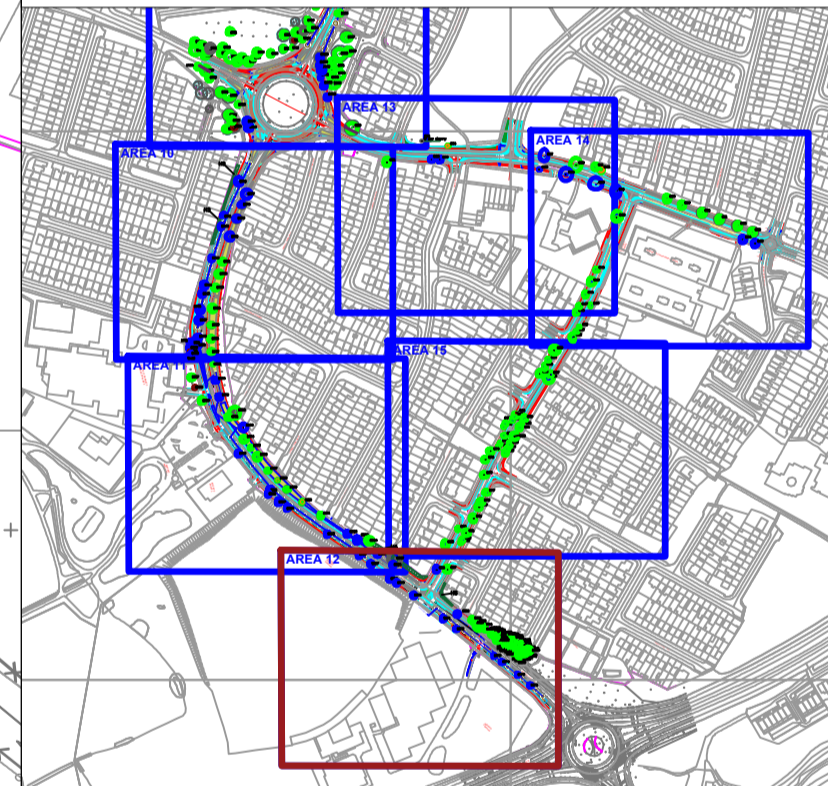

REVISIONS

REV	DATE	DESCRIPTION

PROJECT: Limekiln Road/Templeogue Wood Road/Rossmore Road/Whitehall Road/Wellington Road upgrade

JOB NO. TWEL002

DRAWING: ARBORICULTURAL IMPACT (12of15)

DATE: 31-08-22

SCALE: 1:425 @ A1

DRAWN BY: NIALl MCBRIDE

NMB INITIALS

STATUS: PLANNING

DRAWING NO. 141

REVISION: A

NOTES  
Do Not Scale: Use Figured Dimensions Only  
Not for Construction Purposes unless Specifically Marked  
© THIS DRAWING IS COPYRIGHT OF CMK HORTICULTURE + ARBORICULTURE LTD.

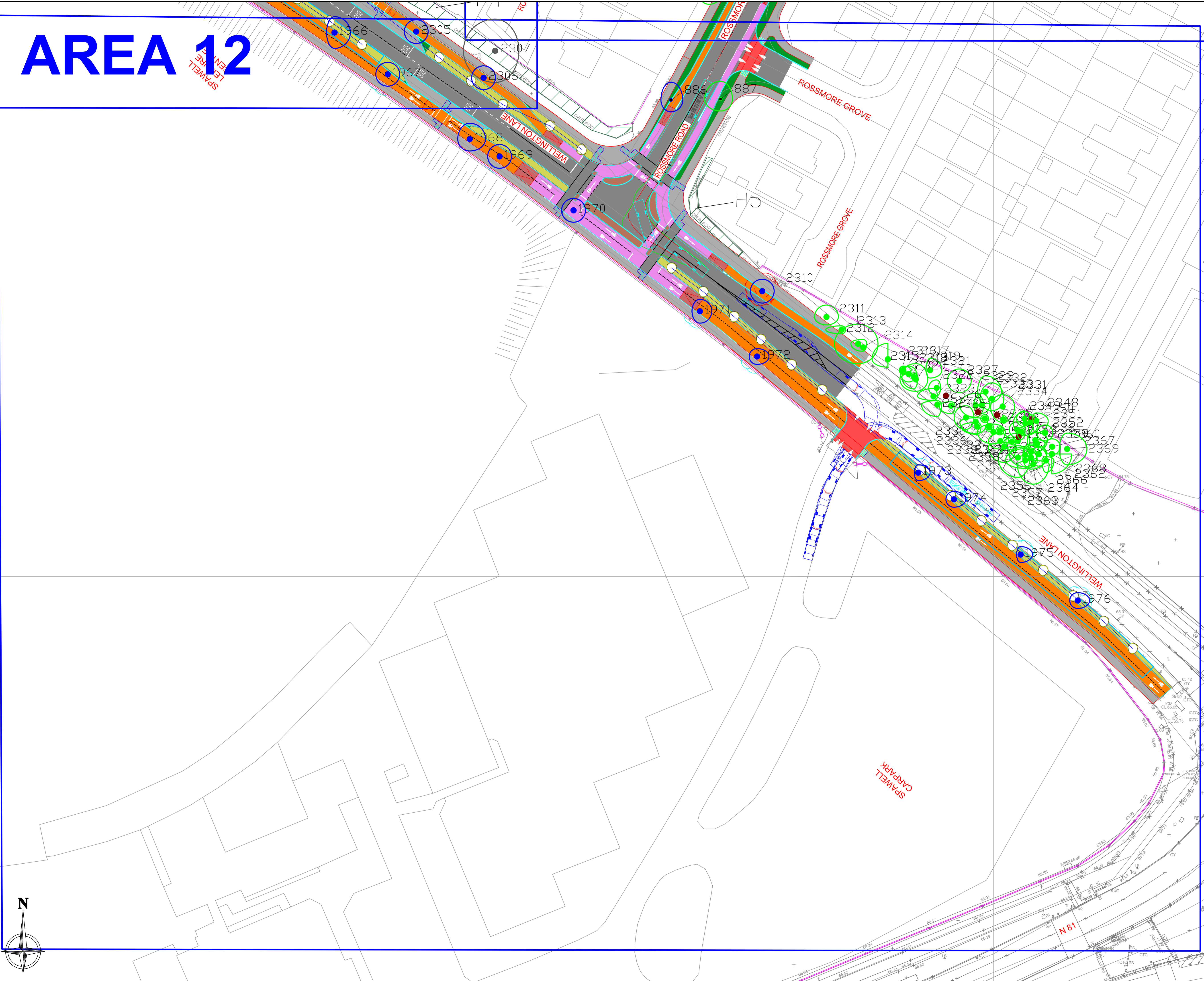
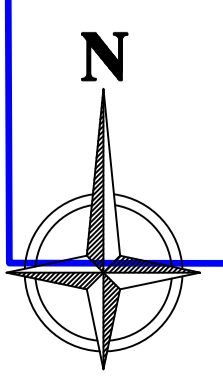

# AREA 13

# AREA 14

CLIENT



ENGINEERS



LEGEND

**TREE CONDITION CATEGORIES**

- TREES TO BE RETAINED
- TREES TO REMOVE TO FACILITATE CONSTRUCTION
- TREES OF VERY LOW VALUE AND QUALITY TO BE REMOVED IN THE INTERESTS OF SOUND ARBORICULTURAL MANAGEMENT

- CELL WEB
- TREE CONSTRAINTS

Drawing to be interpreted with reference to Tree Survey document  
AP refers to approximate position

Tree constraints shown are calculated from guidelines contained within BS5837 (2012) within dimensions contained within Section 8 of the Tree Survey document. This outline should not be interpreted as the exact extent of root spread however it is considered the optimal area to be retained free of developmental impacts. Natural and/or man made barriers such as waterlogged soil or buildings may restrict the spread of tree roots. Crown spreads may also prove to be a constraint particularly where crown reduction may not be possible. The constraints lines shown on this drawing are therefore a guide only. An on-site assessment should be undertaken in the event of any developments being planned within the areas shown for retained trees.

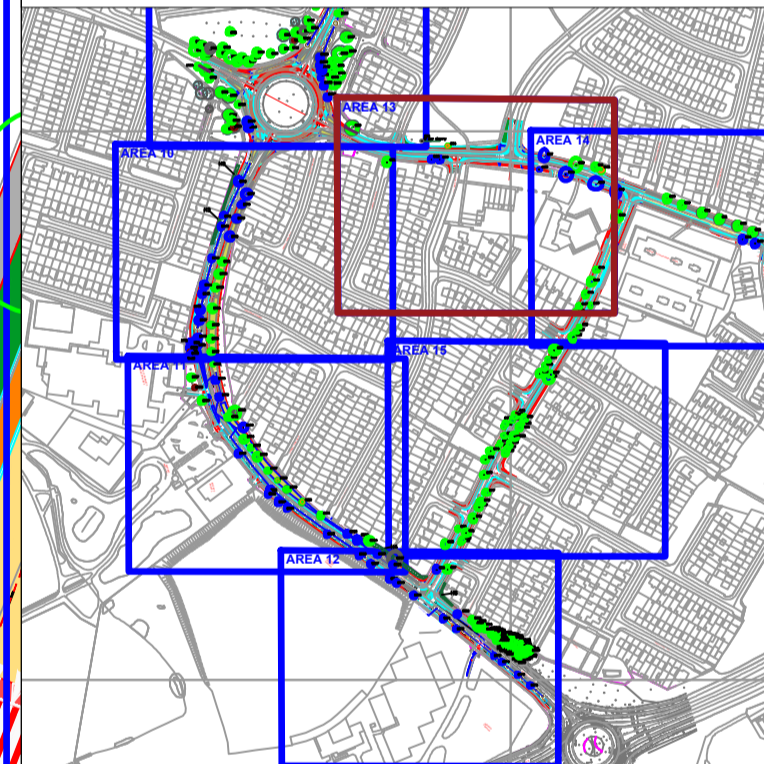

**REVISIONS**

REV	DATE	DESCRIPTION

<b>PROJECT:</b> Limekin Road/Templeogue Wood Road/Rossmore Road/Whitehall Road/ Wellington Road upgrade		<b>JOB NO.:</b> TWEL002
<b>DRAWING:</b> ARBORICULTURAL IMPACT (13of15)	<b>DATE:</b> 31-08-22	<b>SCALE:</b> 1:425 @ A1
<b>DRAWN BY:</b> NIALl MCBRIDE		<b>NMB</b> INITIALS
<b>STATUS:</b> PLANNING		<b>REVISION:</b> A
<b>DRAWING NO. 142</b>		

**NOTES**  
Do Not Scale - Use Figured Dimensions Only  
Not for Construction Purpose unless Specifically Marked  
© THIS DRAWING IS COPYRIGHT OF CMK HORTICULTURE + ARBORICULTURE LTD.

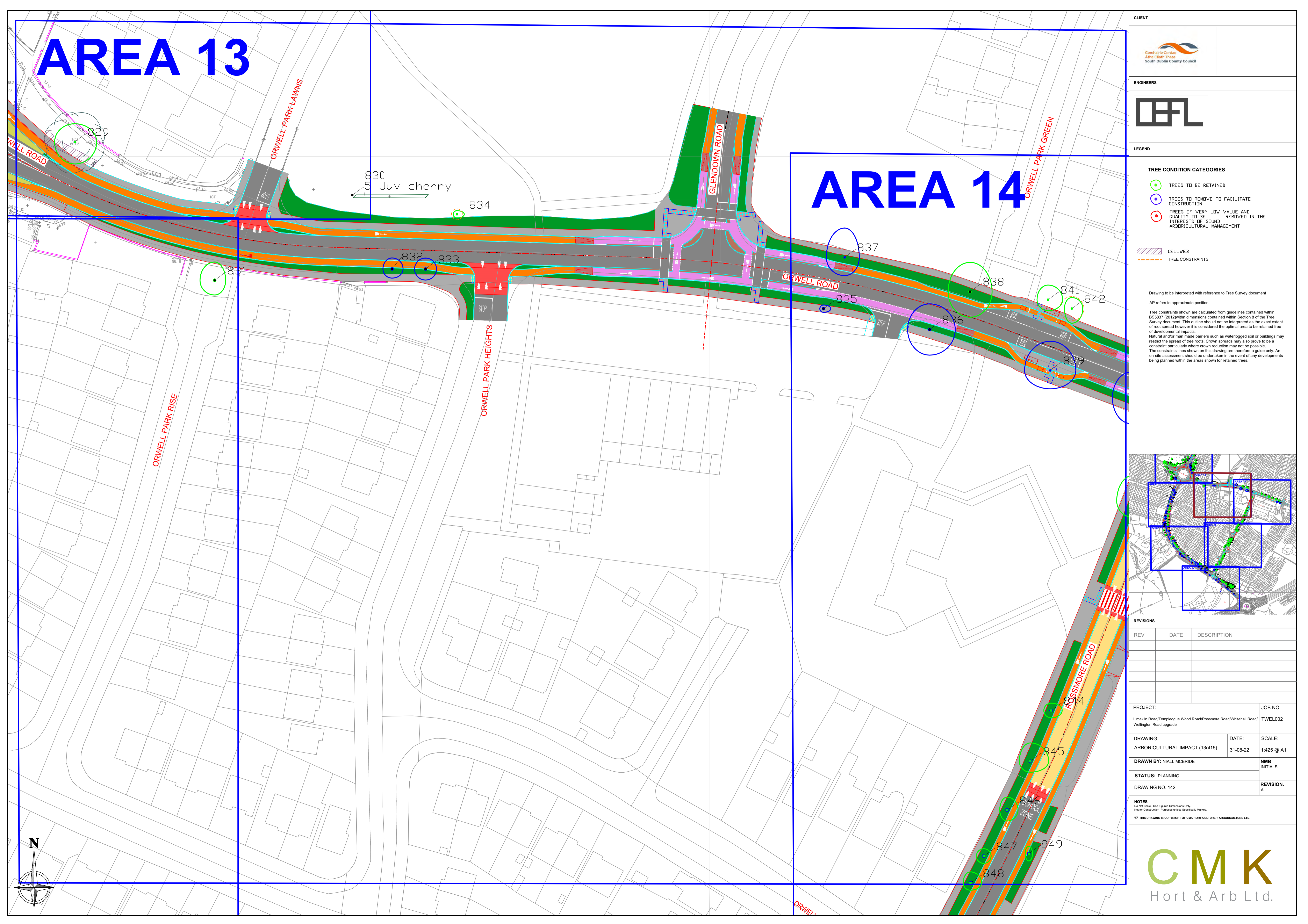
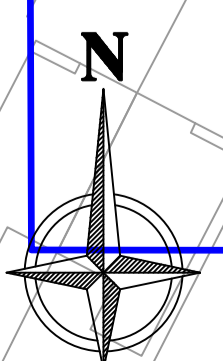



# AREA 14

CLIENT



ENGINEERS



LEGEND

- TREE CONDITION CATEGORIES**
- TREES TO BE RETAINED
  - TREES TO REMOVE TO FACILITATE CONSTRUCTION
  - TREES OF VERY LOW VALUE AND QUALITY TO BE REMOVED IN THE INTERESTS OF SOUND ARBORICULTURAL MANAGEMENT

- CELL WEB
- TREE CONSTRAINTS

Drawing to be interpreted with reference to Tree Survey document  
AP refers to approximate position

Tree constraints shown are calculated from guidelines contained within BS5837 (2012) within dimensions contained within Section 8 of the Tree Survey document. This outline should not be interpreted as the exact extent of root spread however it is considered the optimal area to be retained free of developmental impacts. Natural and/or man made barriers such as waterlogged soil or buildings may restrict the spread of tree roots. Crown spreads may also prove to be a constraint particularly where crown reduction may not be possible. The constraints lines shown on this drawing are therefore a guide only. An on-site assessment should be undertaken in the event of any developments being planned within the areas shown for retained trees.

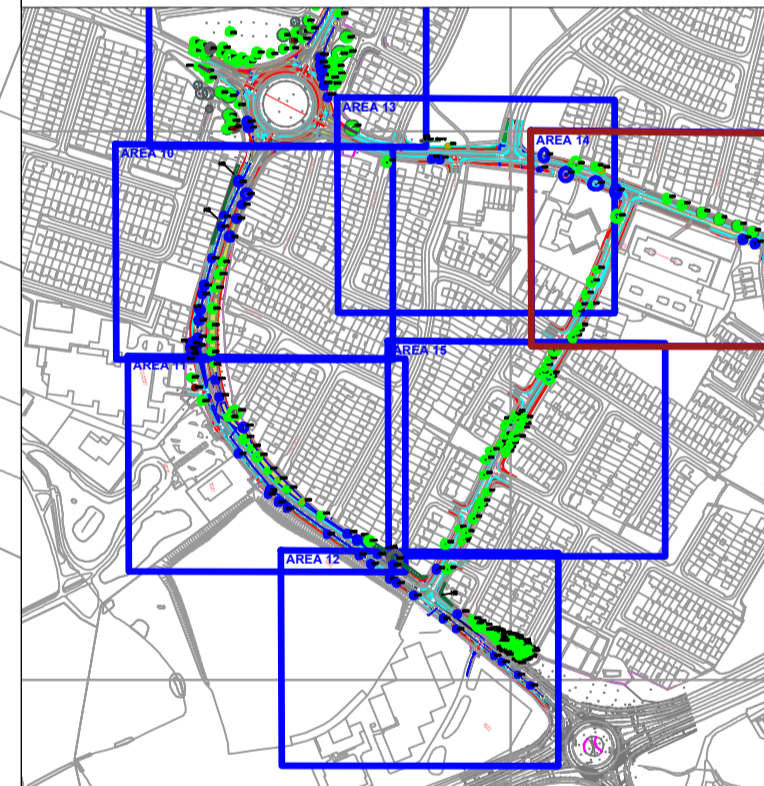

REVISIONS

REV	DATE	DESCRIPTION

PROJECT: Limekin Road/ Templeogue Wood Road/Rossmore Road/Whitehall Road/Wellington Road upgrade

JOB NO. TWEL002

DRAWING: ARBORICULTURAL IMPACT (14of15)

DATE: 31-08-22

SCALE: 1:425 @ A1

DRAWN BY: NIALl MCBRIDE

NMB INITIALS

STATUS: PLANNING

DRAWING NO. 143

REVISION: A

NOTES  
Do Not Scale - Use Figured Dimensions Only  
Not for Construction Purpose unless Specifically Marked  
© THIS DRAWING IS COPYRIGHT OF CMK HORTICULTURE + ARBORICULTURE LTD.

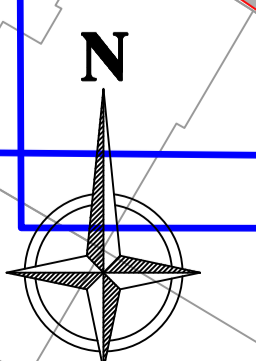
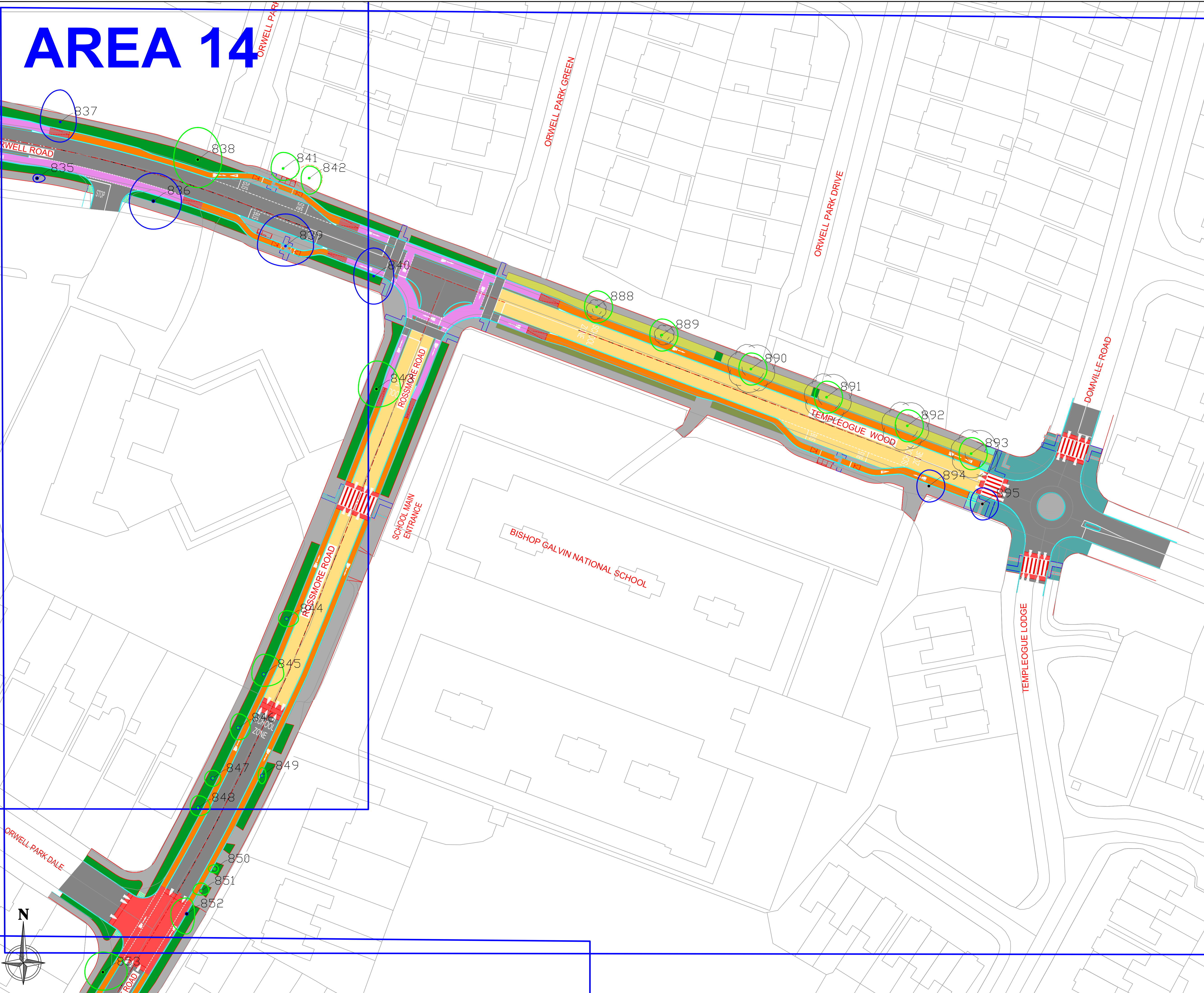

# AREA 15

CLIENT



ENGINEERS



LEGEND

- TREE CONDITION CATEGORIES**
- TREES TO BE RETAINED
  - TREES TO REMOVE TO FACILITATE CONSTRUCTION
  - TREES OF VERY LOW VALUE AND QUALITY TO BE REMOVED IN THE INTERESTS OF SOUND ARBORICULTURAL MANAGEMENT

- CELL WEB
- TREE CONSTRAINTS

Drawing to be interpreted with reference to Tree Survey document  
AP refers to approximate position

Tree constraints shown are calculated from guidelines contained within BS5837 (2012) within dimensions contained within Section 8 of the Tree Survey document. This outline should not be interpreted as the exact extent of root spread however it is considered the optimal area to be retained free of developmental impacts. Natural and/or man made barriers such as waterlogged soil or buildings may restrict the spread of tree roots. Crown spreads may also prove to be a constraint particularly where crown reduction may not be possible. The constraints lines shown on this drawing are therefore a guide only. An on-site assessment should be undertaken in the event of any developments being planned within the areas shown for retained trees.

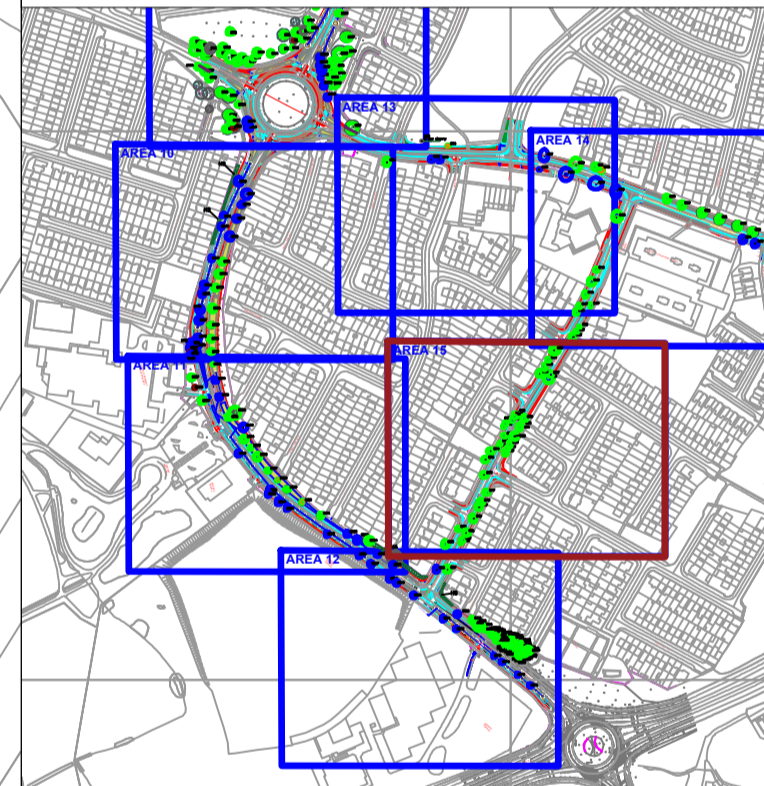

REVISIONS

REV	DATE	DESCRIPTION

PROJECT: Limekiln Road/Templeogue Wood Road/Rossmore Road/Whitehall Road/Wellington Road upgrade

JOB NO. TWEL002

DRAWING: ARBORICULTURAL IMPACT (15of15)

DATE: 31-08-22

SCALE: 1:425 @ A1

DRAWN BY: NIALL MCBRIDE

NMB INITIALS

STATUS: PLANNING

REVISION: A

DRAWING NO. 144

NOTES  
Do Not Scale - Use Figured Dimensions Only  
Not for Construction Purpose unless Specifically Marked  
© THIS DRAWING IS COPYRIGHT OF CMK HORTICULTURE + ARBORICULTURE LTD.

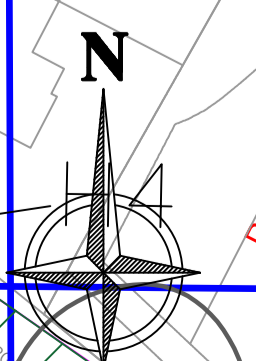

2024